



PNEUMAX S.p.A.
 COMPONENTS FOR PNEUMATIC AUTOMATION

Certified
 Quality System



ISO 9001:2008
 ISO 14001:2004
 OHSAS 18001:2007
 Reg. No. 10677

Innovation "on air"

24050 LURANO (BG) ITALY - Via Cascina Barbellina, 10
 Tel. 035/4192777 - Telefax 035/4192740 - 4192741 - www.pneumaxspa.com

New air treatment units series

Easy assembly, flexibility, design, performance and competitive pricing; these are just some of the main features of the new Pneumax Spa FRL units.

The AIRPLUS series has been designed with the aid of the latest design and manufacturing technologies in order to achieve high performance and to simplify and speed up the installation process.

The new modular structure and connecting system based on dedicated technopolymer flanges ensure maximum flexibility and easy, fast installation. This new system allows the replacement, addition, or removal of one or more modules without the need to disassemble the entire unit.

The use of high performance technopolymer materials, combined with the latest design technologies, has resulted in a low weight, high performance product.

Optimization of the internal flow path, with careful revision of all inner components and the introduction of innovative technical solutions has resulted in enhanced flow rates, that in some cases reach 50% over previous models, and the inclusion of new additional features.

Besides the more conventional units, such as the filter, pressure regulator, and lubricator; other functions such as a lockable manual shut-off valve, an electrical or pneumatic shut-off valve, a soft start valve, an air take off, and a pressure switch are also available.

The new AIRPLUS series is available in three sizes with either moulded technopolymer threaded connections or with threaded metal inserts in sizes G1/8" to G1/2" and with flow rates up to 5,000 NI/min.

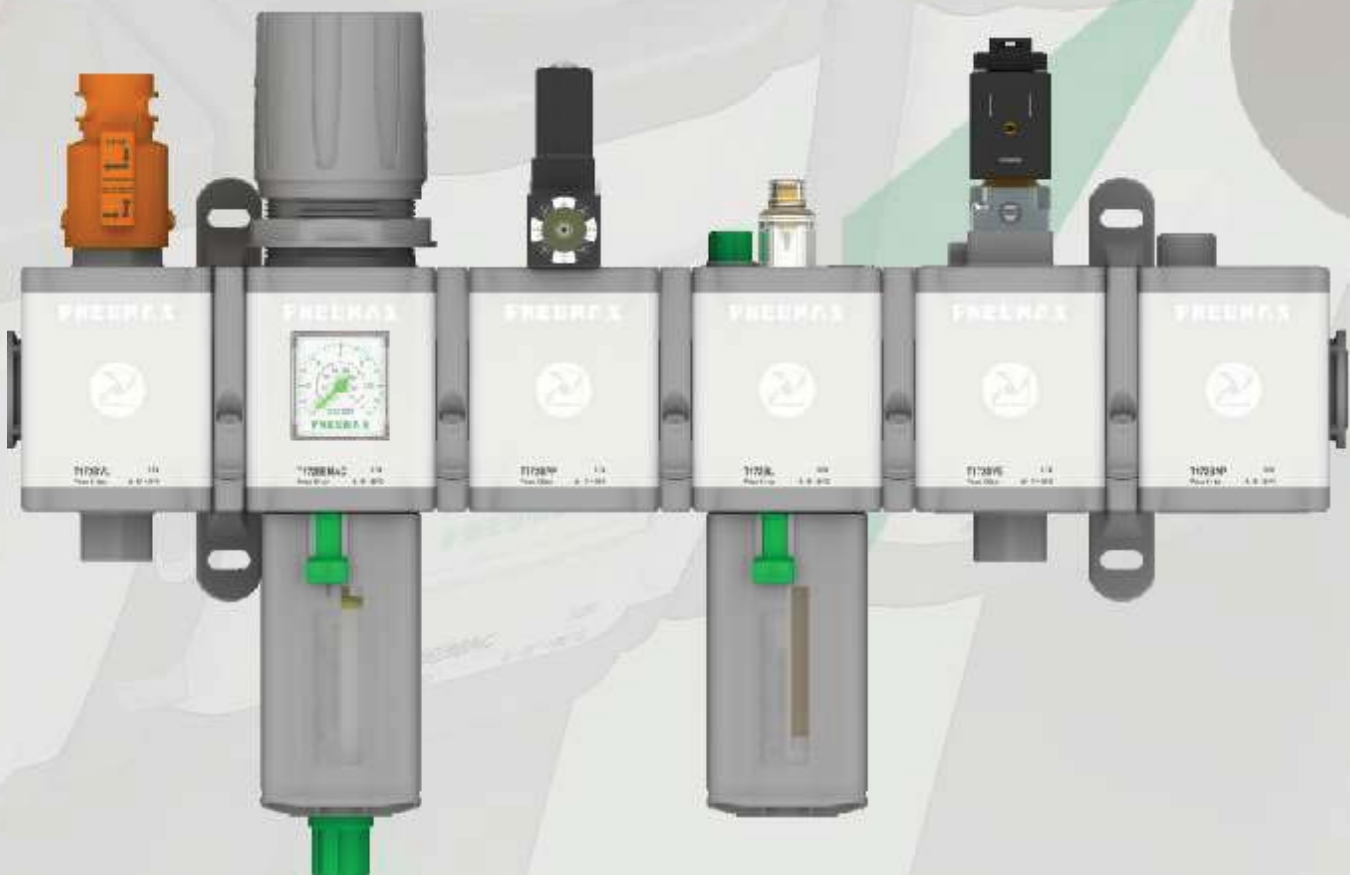

SIZE
3



G 1/2"

SIZE
2



G 3/8"

SIZE
1



G 1/4"

43

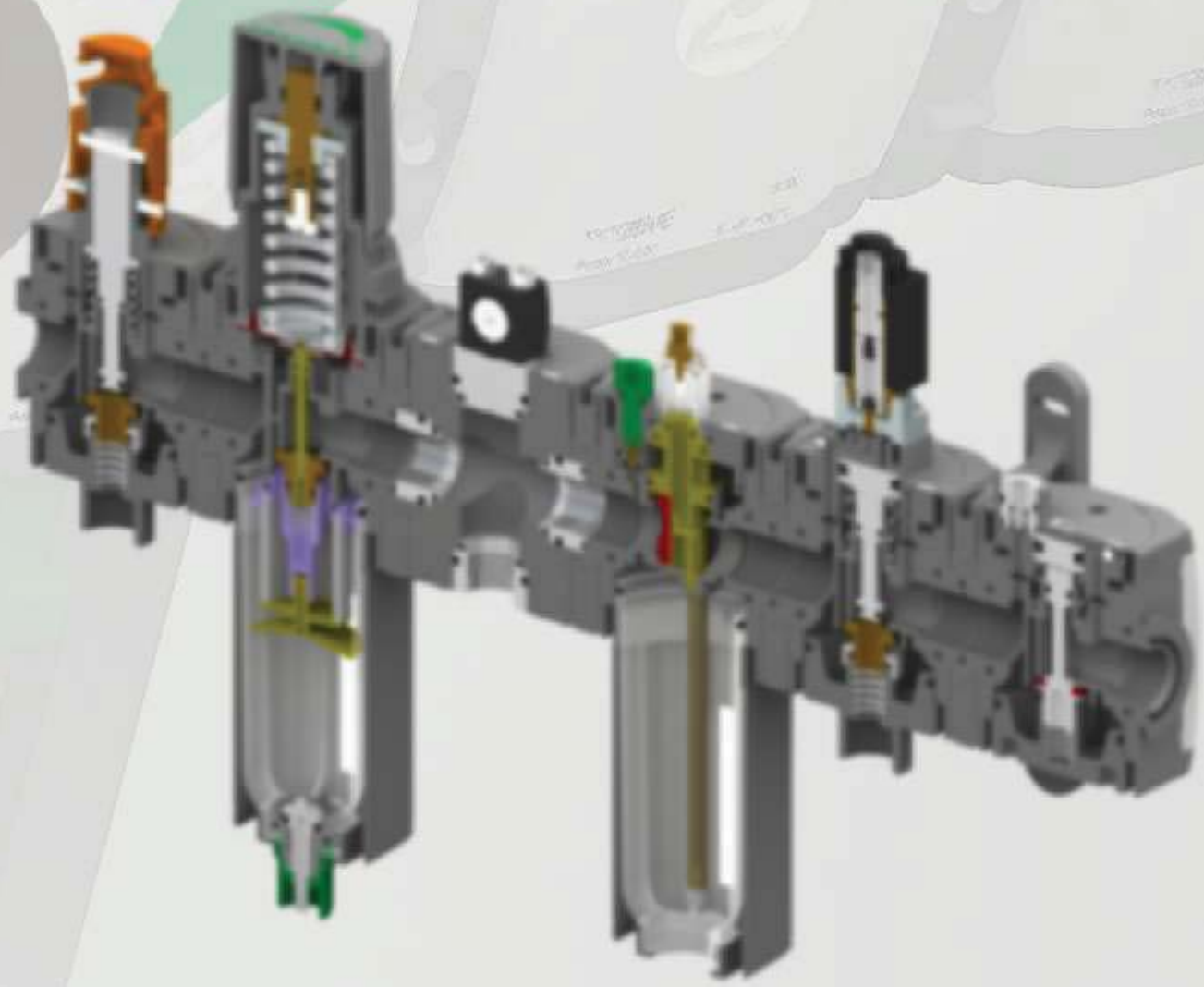

treatment components



"on air"

is subject to change without prior notice

MATERIALS

High performance technopolymer ensures high flows, light weight and reliability.

Moulded technopolimer threaded connections or alternatively threaded metal inserts

DESIGN, PERFORMANCE AND RELIABILITY

New eye catching design. Performance increased by up to 50% compared with the previous series.



NEW

BUILT IN PRESSURE GAUGE

A dedicated built in pressure gauge which ensures space savings is available as an alternative to the conventional pressure gauge for the pressure regulator and filter regulator.



New full range of air

Innovation

Con riserva di modifiche / Specifications may vary

EASY AND FAST INSTALLATION

Modules are coupled together using quick connecting technopolymer flanges (locked with just one screw) which include the option to panel mount.

FLEXIBILITY

The modular structure ensures maximum flexibility. The assembly, disassembly or removal of a component from the FRL group can be easily carried out without the need of removing the group from its mounting position.

NEW

OIL REFILL

The lubricator (size 2 & 3) can be refilled while the unit is pressurised simply following three steps as indicated

- unscrew plug ①
- remove bowl ②
- Refill ③
- re assemble the bowl ②
- screw plug ①

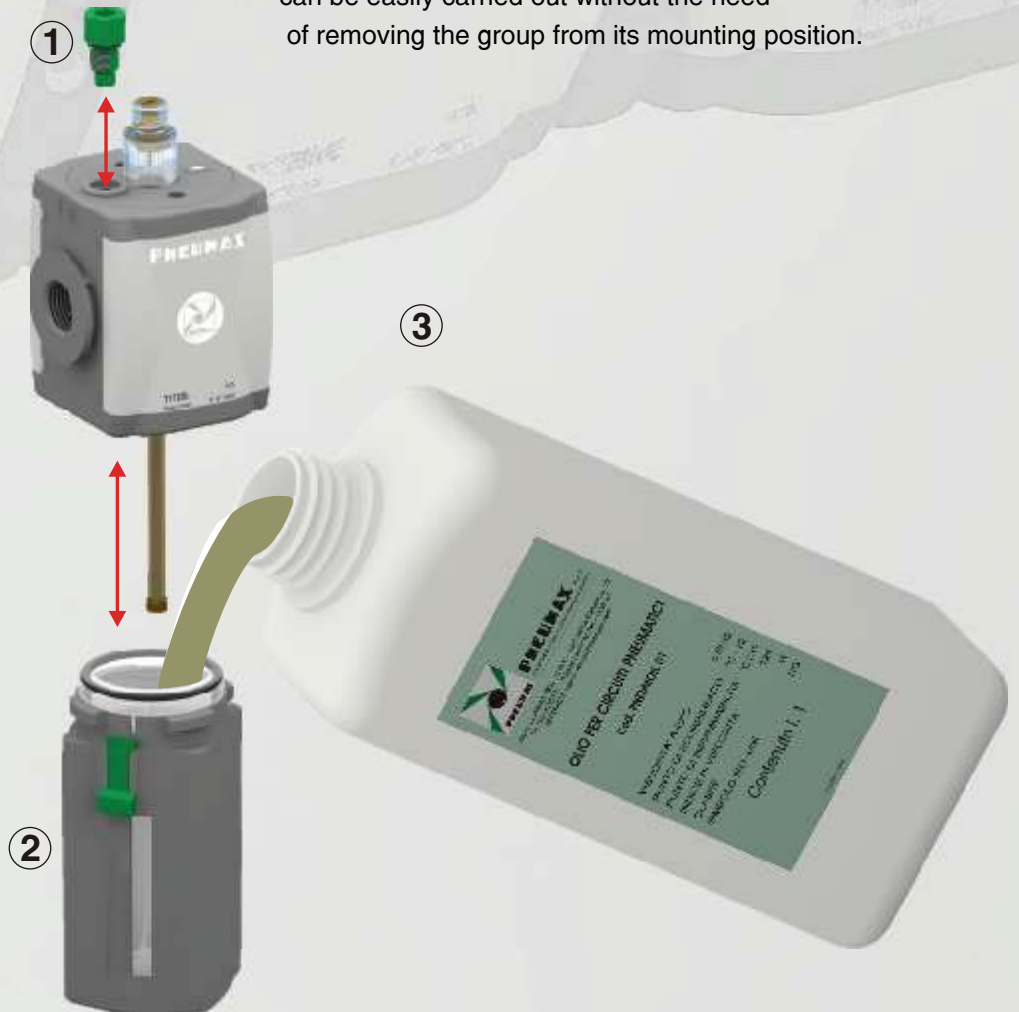

treatment components



"on air"

is subject to change without prior notice

Filter (F)



Example: **T171BFB**
Filter with technopolymer thread, size 1, G1/4 connections, filter pore size 20µ

ORDERING CODE
V 17 1 0 F 3 0
VERSION
N = Metal insert T = Technopolymer thread
SIZE
1 = Size 1 2 = Size 2 3 = Size 3
CONNECTIONS
A = G1/8 - G1/4 - G3/8 (only for insert versions) B = G1/4 - G3/8 - G1/2
FILTER PORE SIZE
A = 5µ B = 20µ C = 50µ
OPTION
Standard S = Automatic drain

	Size 1	Size 2	Size 3
Flow rate**	1650	2200	3500
A	48	62	73
B	40	53	63
C	55	68	80
D	G1/4"	G3/8"	G1/2"
E	42	57	65
F	27,5	34	40
G	92,5	101	127,5
H	147,5	169	207,5
I	120	135	167,5
L*	40	50	65

L* = Minimum clearance required to remove the bowl.
** = Nl/min. (Flow rate at 6 bar with ΔP=1 bar)

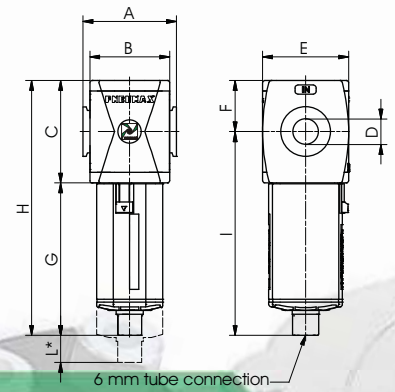

Operational characteristic:

HDPE filter element (high density polyurethane) available with 3 filtering pore size (5µ, 20µ e 50µm). Transparent bowl in polycarbonates (PC) with standard moisture tap and shock resistant protection

Coalescing filter (D)



Example: **T171BDA**
Coalescing filter with technopolymer thread, size 1, G1/4 connections, filter efficiency 99,97%

ORDERING CODE
V 17 1 0 D E 0
VERSION
N = Metal inserts T = Technopolymer thread
SIZE
1 = Size 1 2 = Size 2 3 = Size 3
CONNECTIONS
A = G1/8 - G1/4 - G3/8 (only for insert versions) B = G1/4 - G3/8 - G1/2
FILTER EFFICIENCY
A = 99,97%
OPTION
Standard S = Automatic drain

	Size 1	Size 2	Size 3
Flow rate**	250	500	700
A	48	62	73
B	40	53	63
C	55	68	80
D	G1/4"	G3/8"	G1/2"
E	42	57	65
F	27,5	34	40
G	92,5	101	127,5
H	147,5	169	207,5
I	120	135	167,5
L*	40	50	65

L* = Minimum clearance required to remove the bowl.
= Nl/min. (Flow rate at 6 bar with ΔP=1 bar)

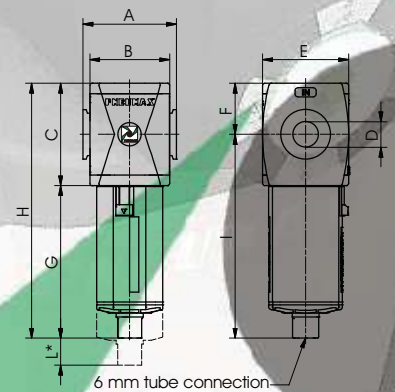

Operational characteristic:

Coalescing filter element with 0.01µm filtering pore size. Transparent bowl in polycarbonates (PC) with standard water drain valve and shock resistant protection

Regulator (R)



Example: **T171BRC**
Regulator with technopolymer thread, size 1, G1/4 connections, adjusting range from 0 to 8 bar.

ORDERING CODE
V 17 1 0 R 0 0
VERSION
N = Metal inserts T = Technopolymer thread
SIZE
1 = Size 1 2 = Size 2 3 = Size 3
CONNECTIONS
A = G1/8 - G1/4 - G3/8 (only for insert versions) B = G1/4 - G3/8 - G1/2
ADJUSTING RANGE
A = 0-2 bar B = 0-4 bar C = 0-8 bar D = 0-12 bar
OPTION
Standard F = Controlled relief + Improved relieving L = Without relieving R = Improved relieving

	Size 1	Size 2	Size 3
Flow rate**	1500	2500	3600
A	48	62	73
B	40	53	63
C	55	68	80
D	G1/4"	G3/8"	G1/2"
E	42	57	65
F	27,5	34	40
G	G1/8"	G1/8"	G1/8"
H	54	71,5	72,5
I	M30x1,5	M42x1,5	M42x1,5
L max.	4	5,5	5,5
M	109	139	152,5

** = Nl/min. (Flow rate at 6 bar with ΔP=1 bar)
(Inlet pressure 7 bar)

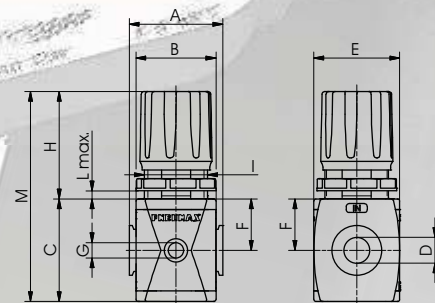

Operational characteristic:

Pressure regulator with working rolling diaphragm with low hysteresis. Balanced system with four operating ranges, up to 12 bar.

Regulator including gauge (RM)

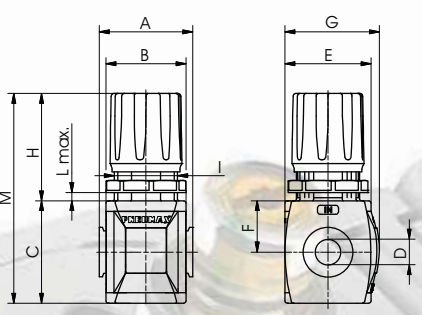

	Size 1	Size 2	Size 3
Flow rate**	1500	2500	3600
A	48	62	73
B	40	53	63
C	55	68	80
D	G1/4"	G3/8"	G1/2"
E	42	57	65
F	27,5	34	40
G	48,5	62,5	70,5
H	54	71,5	72,5
I	M30x1,5	M42x1,5	M42x1,5
L max.	4	5,5	5,5
M	109	139	152,5

**= NI/min. (Flow rate at 6 bar with ΔP=1 bar)
(Inlet pressure 7 bar)

Operational characteristic :
Pressure regulator with working rolling diaphragm with low hysteresis. Balanced system and 4 adjusting range available up to 12 bar. Standard integrated 12 bar gauge

ORDERING CODE	
V 17 T C R M S C C	
VERSION	V N = Metal inserts T = Technopolymer threads
SIZE	1 = Size 1 2 = Size 2 3 = Size 3 4 = Size 4
CONNECTIONS	A = G1/8 - G1/4 - G3/8 (only for insert versions) B = G1/4 - G3/8 - G1/2
ADJUSTING RANGE	A = 0-2 bar B = 0-4 bar C = 0-8 bar D = 0-12 bar
OPTION	Standard F = Controlled relief + Improved relieving L = Without relieving R = Improved relieving

Example: **T171BRMC**
Pressure regulator with technopolymer thread, size 1, G1/4 connections, adjusting range from 0 to 8 bar.

NOTE : Gauge scale 0 + 12 bar



Filter-Regulator (E)

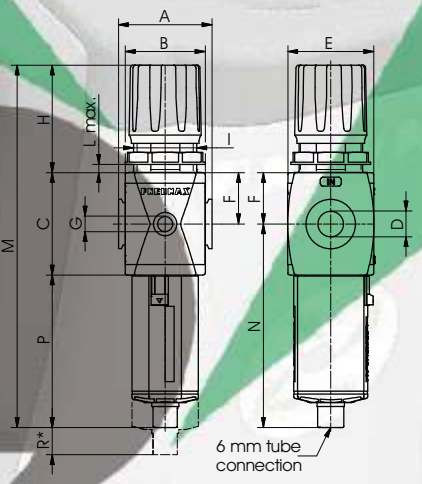

	Size 1	Size 2	Size 3
Flow rate**	1450	2350	3500
A	48	62	73
B	40	53	63
C	55	68	80
D	G1/4"	G3/8"	G1/2"
E	42	57	65
F	27,5	34	40
G	G1/8"	G1/8"	G1/8"
H	54	71,5	72,5
I	M30x1,5	M42x1,5	M42x1,5
L	4	5,5	5,5
M	201,5	240,5	280
N	120	135	167,5
P	92,5	101	127,5
R*	40	50	65

R* = Minimum clearance required to remove the bowl.
** = NI/min. (Flow rate at 6 bar with ΔP=1 bar)
(Inlet pressure 7 bar)

Operational characteristic :
Filter and regulator combining technical and operational characteristics in a single device. Transparent bowl in polycarbonate (PC) with standard water drain valve and shock resistant protection.

ORDERING CODE	
V 17 T C E S C C	
VERSION	V N = Metal inserts T = Technopolymer thread
SIZE	1 = Size 1 2 = Size 2 3 = Size 3
CONNECTIONS	A = G1/8 - G1/4 - G3/8 (only for insert versions) B = G1/4 - G3/8 - G1/2
FILTER PORE SIZE	A = 5µ B = 20µ C = 50µ
ADJUSTING RANGE	A = 0-2 bar B = 0-4 bar C = 0-8 bar D = 0-12 bar
OPTION	Standard S = Automatic drain

Example: **T171BEC**
Filter regulator with technopolymer thread, size 1, G1/4 connections, with 20µ filtering pore size, adjusting range from 0 to 8 bar.



Filter-Regulator including gauge (EM)

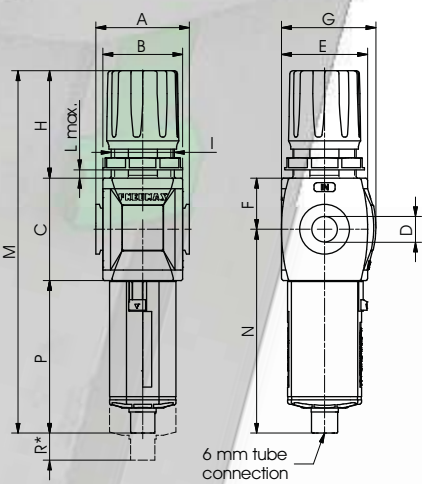

	Size 1	Size 2	Size 3
Flow rate**	1450	2350	3500
A	48	62	73
B	40	53	63
C	55	68	80
D	G1/4"	G3/8"	G1/2"
E	42	57	65
F	27,5	34	40
G	48,5	62,5	70,5
H	54	71,5	72,5
I	M30x1,5	M42x1,5	M42x1,5
L	4	5,5	5,5
M	201,5	240,5	280
N	120	135	167,5
P	92,5	101	127,5
R*	40	50	65

R* = Minimum clearance required to remove the bowl.
** = NI/min. (Flow rate at 6 bar with ΔP=1 bar)
(Inlet pressure 7 bar)

Operational characteristic :
Filter and regulator combining technical and operational characteristics in a single device. Transparent bowl in polycarbonate (PC) with standard water drain valve and shock resistant protection. Standard integrated 0-12 bar gauge

ORDERING CODE	
V 17 T C E M S C C	
VERSION	V N = Metal inserts T = Technopolymer thread
SIZE	1 = Size 1 2 = Size 2 3 = Size 3
CONNECTIONS	A = G1/8 - G1/4 - G3/8 (only for insert versions) B = G1/4 - G3/8 - G1/2
FILTER PORE SIZE	A = 5µ B = 20µ C = 50µ
ADJUSTING RANGE	A = 0-2 bar B = 0-4 bar C = 0-8 bar D = 0-12 bar
OPTION	Standard S = Automatic drain

Example: **T171BEMC**
Filter-Regulator including manometer with technopolymer thread, size 1, G1/4 connections, with 20µ filtering pore size, adjusting range from 0 to 8 bar

NOTE : Gauge scale 0 + 12 bar



Lubricator (L)



ORDERING CODE	
V 17 T C L C	
VERSION	
V	N = Metal insert T = Technopolymer thread
SIZE	
1	= Size 1
2	= Size 2
3	= Size 3
CONNECTIONS	
C	A = G1/8 - G1/4 - G3/8 (only for insert versions) B = G1/4 - G3/8 - G1/2
OPTION	
○	= Standard A = Min. Oil level indicator Normally Open C = Min. Oil level indicator Normally Closed

Example: T171BL
Size 1, G1/4" technopolymer connections lubricator

	Size 1	Size 2	Size 3
Flow rate**	1500	2300	5000
A	48	62	73
B	40	53	63
C	55	68	80
D	G1/4"	G3/8"	G1/2"
E	42	57	65
F	27,5	34	40
G	92,5	101	127,5
H	147,5	169	207,5
I	120	135	167,5
L*	80	90	120
M	24	24	24

L* = Maximum length to disassembly the bowl
** = NI/min. (Flow rate at 6 bar with $\Delta P=1$ bar)

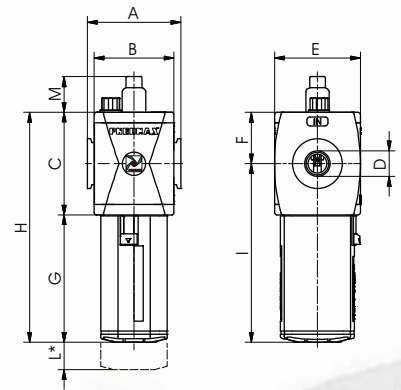

Operational characteristic:

Oil mist lubricator with variable diameter orifice depending on the flow rate. The quantity of oil released in the air stream can be adjusted via the regulating screw and can be checked thanks to the transparent visual dome. The oil refilling process can be carried out while the pneumatic circuit is under pressure (not for size 1)

Shut-off valve (VL)



ORDERING CODE	
V 17 T C VL	
VERSION	
V	N = Metal insert T = Technopolymer thread
SIZE	
1	= Size 1
2	= Size 2
3	= Size 3
CONNECTIONS	
C	A = G1/8 - G1/4 - G3/8 (only for insert versions) B = G1/4 - G3/8 - G1/2

Operational characteristic:
3Way poppet valve.
Manually operated with safety handle both on opening and closing position
Example: T171BVL
Size 1, G1/4" technopolymer connections electric shut off valve

	Size 1	Size 2	Size 3
Flow rate**	1500	2350	3000
Exhaust Flow rate**	950	1600	1600
A	48	62	73
B	40	53	63
C	55	68	80
D	G1/4"	G3/8"	G1/2"
E	42	57	65
F	27,5	34	40
G	11	13,5	13,5
H	55	54	55
I	38,5	47,5	53,5
L	17	20	20
M	121	135,5	148,5
N	G1/4"	G3/8"	G3/8"
P	16	16	16
R	6	6	6

** = NI/min. (Flow rate at 6 bar with $\Delta P=1$ bar)

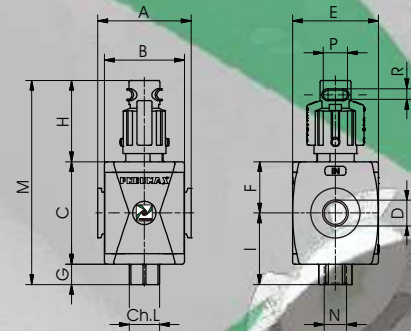

Electric shut-off valve (VE)



ORDERING CODE	
V 17 T C VE A	
VERSION	
V	N = Metal insert T = Technopolymer thread
SIZE	
1	= Size 1
2	= Size 2
3	= Size 3
CONNECTIONS	
C	A = G1/8 - G1/4 - G3/8 (only for insert version) B = G1/4 - G3/8 - G1/2
TENSION	
B2	= Without coil M2 mechanic
B4	= 12 V DC
B5	= 24 V DC
B6	= 24 V AC (50-60 Hz)
B7	= 110 V AC (50-60 Hz)
B8	= 220 V AC (50-60 Hz)
B9	= 24 V DC (2 Watt)

Example: T171BVEB2
Size 1, G1/4" technopolymer connections electric shut off valve, with M2 Pilot without coil

	Size 1	Size 2	Size 3
Flow rate**	1500	2350	3000
Exhaust Flow rate**	950	1600	1600
A	48	62	73
B	40	53	63
C	55	68	80
D	G1/4"	G3/8"	G1/2"
E	42	57	65
F	27,5	34	40
G	11	13,5	13,5
H	61	64	61
I	38,5	47,5	53,5
L	17	20	20
M	127	145,5	154,5
N	G1/4"	G3/8"	G3/8"

** = NI/min. (Flow rate at 6 bar with $\Delta P=1$ bar)

Operational characteristic:
3 ways poppet valve
Low consumption coil available

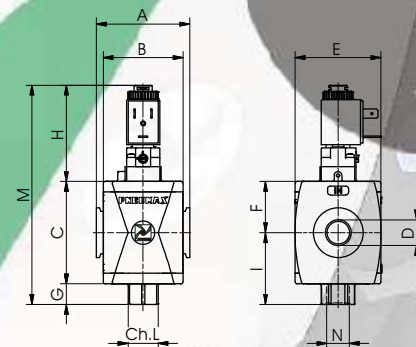

Progressive start-up valve (AP)



ORDERING CODE	
V 17 T C AP	
VERSION	
V	N = Metal insert T = Technopolymer thread
SIZE	
1	= Size 1
2	= Size 2
3	= Size 3
CONNECTIONS	
C	A = G1/8 - G1/4 - G3/8 (only for insert versions) B = G1/4 - G3/8 - G1/2

Example: N171BAP
Size 1, G1/4" technopolymer connections progressive start up valve

	Size 1	Size 2	Size 3
Flow rate**	1500	2350	3500
A	48	62	73
B	40	53	63
C	55	68	80
D	G1/4"	G3/8"	G1/2"
E	42	57	65
F	27,5	34	40
G	67	77	88,5
H	12	9	8,5

** = NI/min. (Flow rate at 6 bar with $\Delta P=1$ bar)

Operational characteristic:

Thanks to the built in flow regulator it is possible to regulate the down stream circuit filling time.
The full flow rate is allowed once the 50% of the inlet pressure is reached on the downstream circuit.

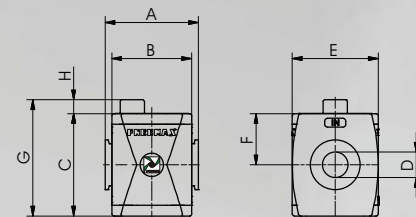

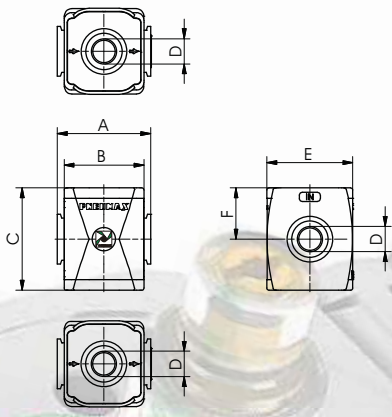

	Size 1	Size 2	Size 3
A	48	62	73
B	40	53	63
C	55	68	80
D	G1/4"	G3/8"	G1/2"
E	42	57	65
F	27,5	34	40

ORDERING CODE	
N 17 PA	
SIZE	
1	1 = Size 1
2	2 = Size 2
3	3 = Size 3
CONNECTIONS	
A	A = G1/8 - G1/4 - G3/8
B	B = G1/4 - G3/8 - G1/2



Air intake
(PA)

Operational characteristic :
Available with two threaded connections

Example : **N171BPA**
Size 1, G1/4" connections air intake

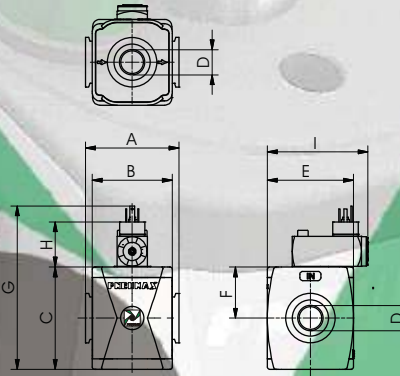

	Size 1	Size 2	Size 3
A	48	62	73
B	40	53	63
C	55	68	80
D	G1/4"	G3/8"	G1/2"
E	42	57	65
F	27,5	34	40
G	101,5	108,5	120,5
H	26,5	30	30
I	53	67	71

ORDERING CODE	
N 17 PP	
SIZE	
1	1 = Size 1
2	2 = Size 2
3	3 = Size 3
CONNECTIONS	
A	A = G1/8 - G1/4 - G3/8
B	B = G1/4 - G3/8 - G1/2



Pressure switch
(PP)

Operational characteristic :
Adjustable pressure switch (2 to 10 bar) with integrated electrical connector
Threaded connection available on the lower side

Example : **N171BPP**
Size 1, G1/4" connections pressure switch

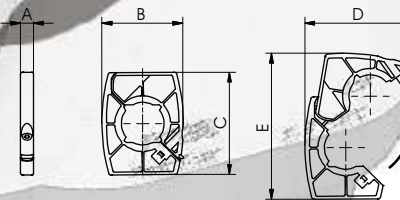

	Size 1	Size 2	Size 3
A	7,8	8,7	9,7
B	40	53,5	62
C	55	68	80
D	56,5	85,5	86,5
E	74	97	113

ORDERING CODE	
T.17 X	
SIZE	
1	1 = Size 1
2	2 = Size 2
3	3 = Size 3



Coupling flange
(X)

Operational characteristic :
Enables the quick connection of two functions

Example : **T171X**
Size 1 coupling flange

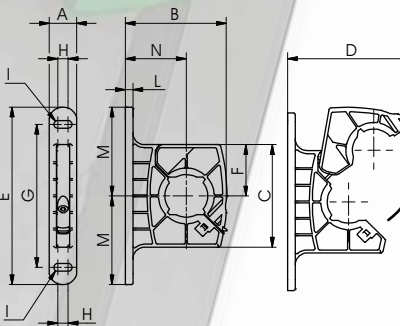

	Size 1	Size 2	Size 3
A	14	18	18
B	50,5	67,5	75,5
C	55	68	80
D	67	85,5	100
E	95	118	133
F	27,5	34	40
G	80	95	110
H	3	6,8	6,8
I	Ø4,5	Ø5,2	Ø5,2
L	4	5	5
M	47,5	59	66,5
N	30,5	40,5	44,5

ORDERING CODE	
T 17 Y	
SIZE	
1	1 = Size 1
2	2 = Size 2
3	3 = Size 3



Coupling flange with mounting holes
(Y)

Operational characteristic :
Enables the quick connection of two functions and allows for panel mounting.

Example : **T171Y**
Size 1 coupling flange with mounting holes

treatment components



"on air"

is subject to change without prior notice

Service unit assembled
(EM+L)

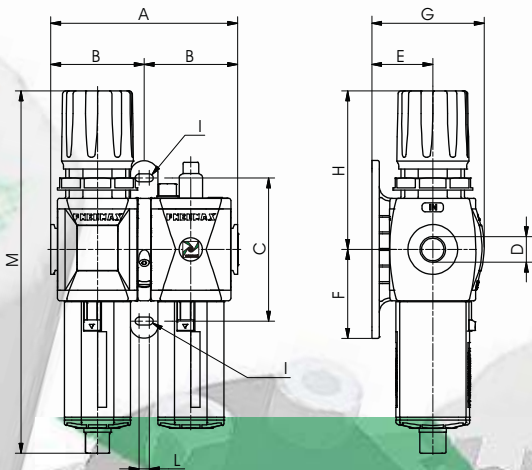

Filter-regulator, Lubricator

Operational characteristic :
Combined group comprising filter - regulator with built in manometer and lubricator assembled with a (Y) type coupling kit for panel mounting.
Built in gauge 0 to 12 bar as standard

Example : **GT171BHG**
Size 1 Combined group comprising G1/4" technopolymer connection filter-regulator and lubricator, 0 to 8bar regulating range and 20 µ filtering element

NOTE: pressure gauge range 0 to 12 bar

ORDERING CODE
G V 17 T C H S O
VERSION
V = Metal insert T = Technopolymer thread
SIZE
1 = Size 1 2 = Size 2 3 = Size 3
CONNECTIONS
A = G1/8 - G1/4 - G3/8 (only for insert versions) B = G1/4 - G3/8 - G1/2
FILTER PORE SIZE ADJUSTING RANGE
C = 5µ / 0-8 bar D = 5µ / 0-12 bar G = 20µ / 0-8 bar H = 20µ / 0-12 bar N = 50µ / 0-8 bar P = 50µ / 0-12 bar
OPTION
Standard A = Min.oil level indicator NO C = Min.oil level indicator NC S = Automatic drain SA= Automatic drain + min.oil level indicator NO SC= Automatic drain + min.oil level indicator NC

	Size 1	Size 2	Size 3
A	96	124	146
B	48	62	73
C	80	95	110
D	G1/4"	G3/8"	G1/2"
E	30,5	40,5	44,5
F	47,5	59	66,5
G	58	74,5	82,5
H	81,5	105	112,5
I	Ø4,5	Ø5,2	Ø5,2
L	3	6,8	6,8
M	201,5	240,5	280

Service unit assembled
(F+RM+L)

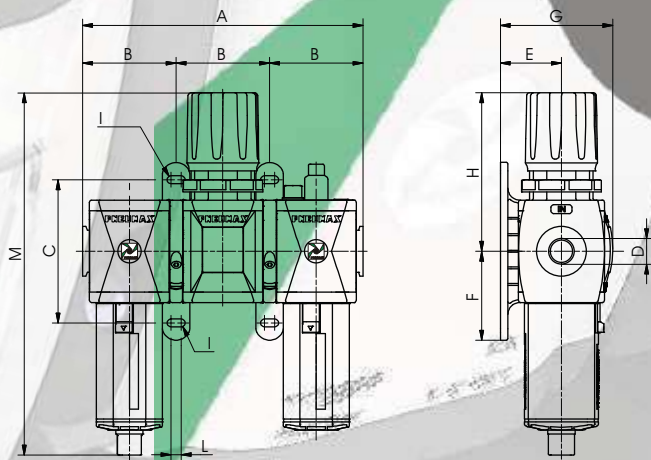

Filter, Pressure regulator, Lubricator

Operational characteristic :
Combined group comprising Filter, Regulator with built in manometer and Lubricator assembled with two (Y) type coupling kits for panel mounting.
Built in gauge 0 to 12 bar as standard

Example : **GT171BKG**
Size 1 Combined group comprising G1/4" technopolymer connection Filter, Regulator and Lubricator, 0 to 8 bar regulating range and 20 µ filtering element

NOTE: pressure gauge range 0 to 12 bar

ORDERING CODE
G V 17 T C K S O
VERSION
V = Metal insert T = Technopolymer thread
SIZE
1 = Size 1 2 = Size 2 3 = Size 3
CONNECTIONS
A = G1/8 - G1/4 - G3/8 (only for insert versions) B = G1/4 - G3/8 - G1/2
FILTER PORE SIZE ADJUSTING RANGE
C = 5µ / 0-8 bar D = 5µ / 0-12 bar G = 20µ / 0-8 bar H = 20µ / 0-12 bar N = 50µ / 0-8 bar P = 50µ / 0-12 bar
OPTION
Standard A = Min.oil level indicator NO C = Min.oil level indicator NC S = Automatic drain SA= Automatic drain + min.oil level indicator NO SC= Automatic drain + min.oil level indicator NC

	Size 1	Size 2	Size 3
A	144	186	219
B	48	62	73
C	80	95	110
D	G1/4"	G3/8"	G1/2"
E	30,5	40,5	44,5
F	47,5	59	66,5
G	58	74,5	82,5
H	81,5	105	112,5
I	Ø4,5	Ø5,2	Ø5,2
L	3	6,8	6,8
M	201,5	240,5	280



New full range of air

Innovation

Con riserva di modifiche / Specifications may

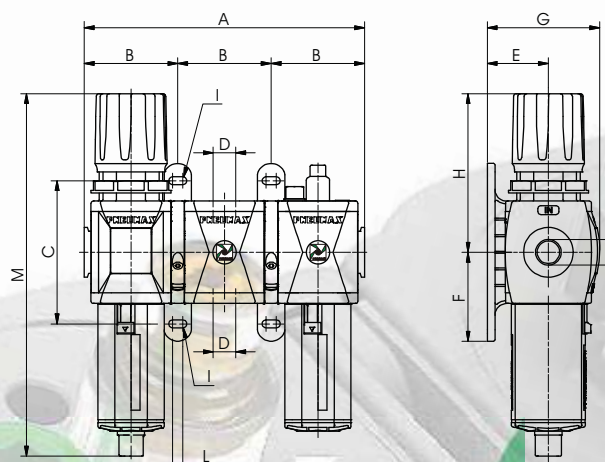

Filter-regulator, Air intake, Lubricator

Operational characteristic :
 Combined group comprising filter-regulator with built in manometer, air intake and lubricator assembled with two (Y) type coupling kits for panel mounting.
 Built in gauge 0 to 12 bar as standard

	Size 1	Size 2	Size 3
A	144	186	219
B	48	62	73
C	80	95	110
D	G1/4"	G3/8"	G1/2"
E	30,5	40,5	44,5
F	47,5	59	66,5
G	58	74,5	82,5
H	81,5	105	112,5
I	Ø4,5	Ø5,2	Ø5,2
L	3	6,8	6,8
M	201,5	240,5	280

Example : GT171BNG
 Size 1 Combined group comprising G1/4" technopolymer connection filter-regulator and lubricator, 0 to 8bar regulating range and 20 µ filtering element

NOTE: pressure gauge range 0 to 12 bar

ORDERING CODE	
G V 17 T C N S O	
VERSION	
V	N = Metal insert T = Technopolymer thread
SIZE	
T	1 = Size 1 2 = Size 2 3 = Size 3
CONNECTIONS	
C	A = G1/8 - G1/4 - G3/8 (only for insert versions) B = G1/4 - G3/8 - G1/2
FILTER PORE SIZE ADJUSTING RANGE	
C	C = 5µ / 0-8 bar
D	D = 5µ / 0-12 bar
G	G = 20µ / 0-8 bar
H	H = 20µ / 0-12 bar
N	N = 50µ / 0-8 bar
P	P = 50µ / 0-12 bar
OPTION	
Standard	
A	A = Min.oil level indicator NO
C	C = Min.oil level indicator NC
S	S = Automatic drain
SA	SA= Automatic drain + min.oil level indicator NO
SC	SC= Automatic drain + min.oil level indicator NC

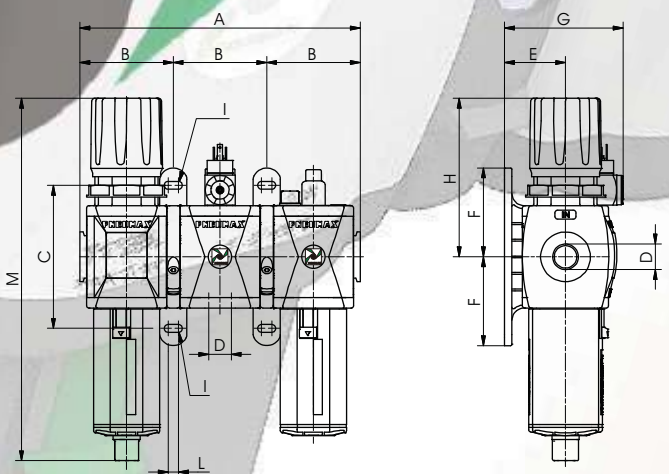

Filter - Regulator, Pressure switch, Lubricator

Operational characteristic :
 Combined group comprising filter-regulator with built in manometer, pressure switch and lubricator assembled with two Y type coupling kits for panel mountings.
 Built in gauge 0 to 12 bar as standard

	Size 1	Size 2	Size 3
A	144	186	219
B	48	62	73
C	80	95	110
D	G1/4"	G3/8"	G1/2"
E	30,5	40,5	44,5
F	47,5	59	66,5
G	62,5	79	83
H	81,5	105	112,5
I	Ø4,5	Ø5,2	Ø5,2
L	3	6,8	6,8
M	201,5	240,5	280

Example : GT171BRG
 Size 1 Combined group comprising G1/4" technopolymer connection Filter-Regulator, pressure switch and Lubricator, 0 to 8 bar regulating range and 20 µ filtering element

NOTE: pressure gauge range 0 to 12 bar

ORDERING CODE	
G V 17 T C R S O	
VERSION	
V	N = Metal insert T = Technopolymer thread
SIZE	
T	1 = Size 1 2 = Size 2 3 = Size 3
CONNECTIONS	
C	A = G1/8 - G1/4 - G3/8 (only for insert versions) B = G1/4 - G3/8 - G1/2
FILTER PORE SIZE ADJUSTING RANGE	
C	C = 5µ / 0-8 bar
D	D = 5µ / 0-12 bar
G	G = 20µ / 0-8 bar
H	H = 20µ / 0-12 bar
N	N = 50µ / 0-8 bar
P	P = 50µ / 0-12 bar
OPTION	
Standard	
A	A = Min.oil level indicator NO
C	C = Min.oil level indicator NC
S	S = Automatic drain
SA	SA= Automatic drain + min.oil level indicator NO
SC	SC= Automatic drain + min.oil level indicator NC

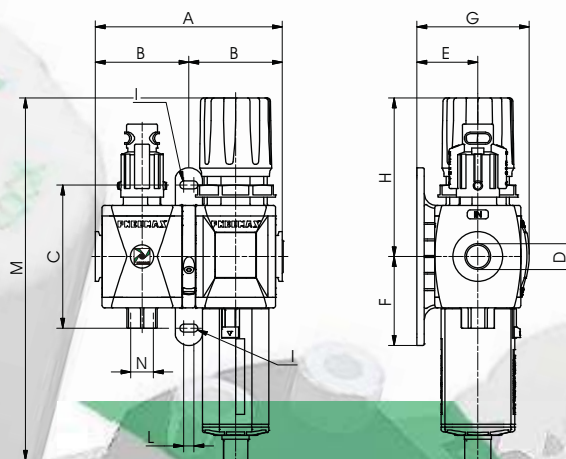

Shut off valve, Filter-regulator

Operational characteristic :

Combined group comprising manual shut off valve, filter - regulator with built in manometer, assembled with one Y type coupling kit for panel mountings.
Built in gauge 0 to 12 bar as standard

Example : **GT171BVGG**

Size 1 Combined group G1/4" technopolymer connections comprising shut off valve, filter-regulator. 0 to 8 bar regulating range and 20 filtering element

NOTE: pressure gauge range 0 to 12 bar

ORDERING CODE	
G 17 1 1 1 V G S 1	
VERSION	
V	N = Metal insert T = Technopolymer thread
SIZE	
1	1 = Size 1 2 = Size 2 3 = Size 3
CONNECTIONS	
G	A = G1/8 - G1/4 - G3/8 (only for insert version) B = G1/4 - G3/8 - G1/2
FILTER PORE SIZE ADJUSTING RANGE	
S	C = 5µ / 0-8 bar D = 5µ / 0-12 bar H = 20µ / 0-8 bar N = 50µ / 0-8 bar P = 50µ / 0-12 bar
OPTION	
1	Standard
S	Automatic drain

	Size 1	Size 2	Size 3
A	96	124	146
B	48	62	73
C	80	95	110
D	G1/4"	G3/8"	G1/2"
E	30,5	40,5	44,5
F	47,5	59	66,5
G	58	74,5	82,5
H	81,5	105	112,5
I	Ø4,5	Ø5,2	Ø5,2
L	3	6,8	6,8
M	201,5	240,5	280
N	G1/4"	G3/8"	G3/8"

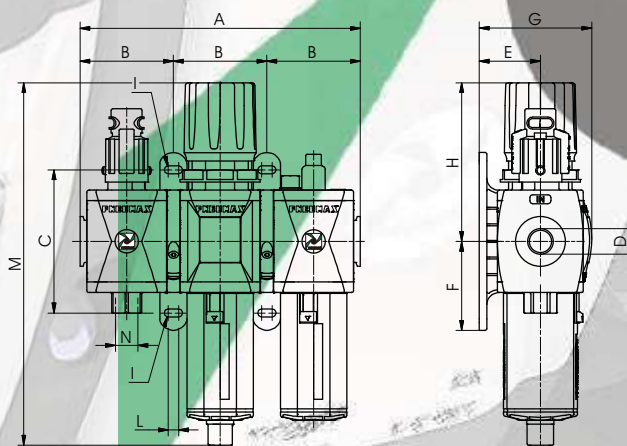

Shut off valve, Filter-regulator, Lubricator

Operational characteristic :

Combined group comprising manual shut off valve, filter - regulator with built in manometer and lubricator assembled with two Y type coupling kits for panel mountings.
Built in gauge 0 to 12 bar as standard

Example : **GT171BVHG**

Size 1 Combined group G1/4" technopolymer connections comprising shut off valve, filter-regulator and lubricator 0 to 8 bar regulating range and 20 filtering element

NOTE: pressure gauge range 0 to 12 bar

ORDERING CODE	
G 17 1 1 1 V H S 1	
VERSION	
V	N = Metal insert T = Technopolymer thread
SIZE	
1	1 = Size 1 2 = Size 2 3 = Size 3
CONNECTIONS	
G	A = G1/8 - G1/4 - G3/8 (only for insert version) B = G1/4 - G3/8 - G1/2
FILTER PORE SIZE ADJUSTING RANGE	
S	C = 5µ / 0-8 bar D = 5µ / 0-12 bar H = 20µ / 0-8 bar N = 50µ / 0-12 bar P = 50µ / 0-8 bar
OPTION	
1	Standard
A	Min.oil level indicator NO
C	Min.oil level indicator NC
S	Automatic drain
SA	Automatic drain + min.oil level indicator NO
SC	Automatic drain + min.oil level indicator NC

	Size 1	Size 2	Size 3
A	144	186	219
B	48	62	73
C	80	95	110
D	G1/4"	G3/8"	G1/2"
E	30,5	40,5	44,5
F	47,5	59	66,5
G	58	74,5	82,5
H	81,5	105	112,5
I	Ø4,5	Ø5,2	Ø5,2
L	3	6,8	6,8
M	201,5	240,5	280
N	G1/4"	G3/8"	G3/8"



New full range of air

Innovation

Con riserva di modifiche / Specifications may

Service unit assembled
(VL+F+RM+L)

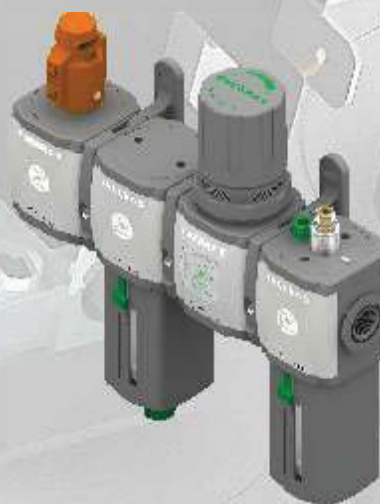
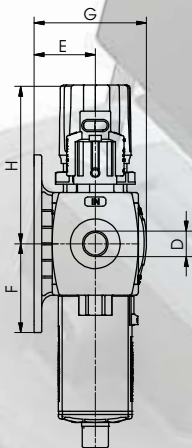
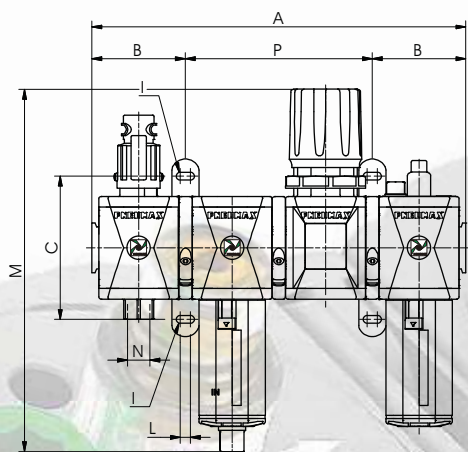

Shut off valve, Filter, Regulator, Lubricator

Operational characteristic :

Combined group comprising manual shut off valve, filter, regulator with built in manometer and lubricator , assembled with two Y type coupling kits for panel mounting and one X type coupling kit.
Built in pressure gauge 0 to 12 bar range

	Size 1	Size 2	Size 3
A	192	248	292
B	48	62	73
C	80	95	110
D	G1/4"	G3/8"	G1/2"
E	30,5	40,5	44,5
F	47,5	59	66,5
G	58	74,5	82,5
H	81,5	105	112,5
I	Ø4,5	Ø5,2	Ø5,2
L	3	6,8	6,8
M	201,5	240,5	280
N	G1/4"	G3/8"	G3/8"
P	96	124	219

Example : **GT171BVKG**

Size 1 Combined group G1/4" technopolymer connections comprising shut off valve, filter, regulator and lubricator. 0 to 8 bar regulating range and 20 filtering element

NOTE: pressure gauge range 0 to 12 bar

ORDERING CODE

G V 17 T C V K S C

VERSION

V N = Metal insert
T = Technopolymer thread

SIZE

1 = Size 1
2 = Size 2
3 = Size 3

CONNECTIONS

A = G1/8 - G1/4 - G3/8 (only for insert versions)
B = G1/4 - G3/8 - G1/2

FILTER PORE SIZE

ADJUSTING RANGE

C = 5µ / 0-8 bar
D = 5µ / 0-12 bar
G = 20µ / 0-8 bar
H = 20µ / 0-12 bar
N = 50µ / 0-8 bar
P = 50µ / 0-12 bar

OPTION

Standard
A = Min.oil level indicator NO
C = Min.oil level indicator NC
S = Automatic drain
SA= Automatic drain + min.oil level indicator NO
SC= Automatic drain + min.oil level indicator NC

Service unit assembled
(VL+EM+PA+L)

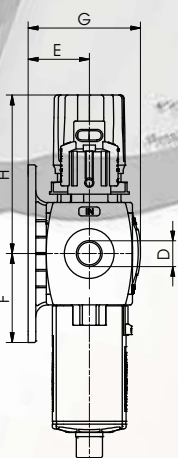
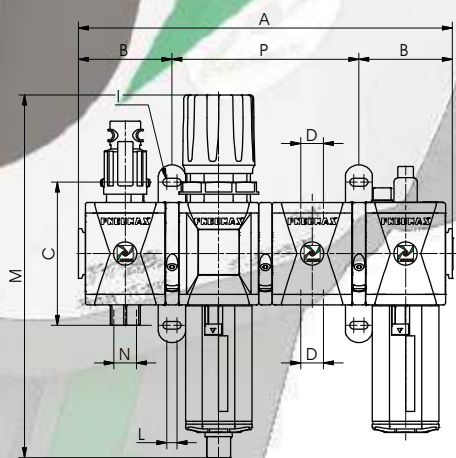

Shut off valve, Filter-regulator Air intake, Lubricator

Operational characteristic :

Combined group comprising manual shut off valve, filter-regulator with built in manometer, air intake and lubricator , assembled with two Y type coupling kits for panel mounting and one X type coupling kit.
Built in pressure gauge 0 to 12 bar range

	Size 1	Size 2	Size 3
A	192	248	292
B	48	62	73
C	80	95	110
D	G1/4"	G3/8"	G1/2"
E	30,5	40,5	44,5
F	47,5	59	66,5
G	58	74,5	82,5
H	81,5	105	112,5
I	Ø4,5	Ø5,2	Ø5,2
L	3	6,8	6,8
M	201,5	240,5	280
N	G1/4"	G3/8"	G3/8"
P	96	124	219

Example : **GT171BVNG**

Size 1 Combined group G1/4" technopolymer connections comprising shut off valve, filter-regulator, air intake and lubricator 0 to 8 bar regulating range and 20 filtering element

NOTE: pressure gauge range 0 to 12 bar

ORDERING CODE

G V 17 T C V N S C

VERSION

V N = Metal insert
T = Technopolymer thread

SIZE

1 = Size 1
2 = Size 2
3 = Size 3

CONNECTIONS

A = G1/8 - G1/4 - G3/8 (only for insert versions)
B = G1/4 - G3/8 - G1/2

FILTER PORE SIZE

ADJUSTING RANGE

C = 5µ / 0-8 bar
D = 5µ / 0-12 bar
G = 20µ / 0-8 bar
H = 20µ / 0-12 bar
N = 50µ / 0-8 bar
P = 50µ / 0-12 bar

OPTION

Standard
A = Min.oil level indicator NO
C = Min.oil level indicator NC
S = Automatic drain
SA= Automatic drain + min.oil level indicator NO
SC= Automatic drain + min.oil level indicator NC

treatment components



"on air"

Subject to change without prior notice

Service unit assembled
(VL+EM+PP+L)

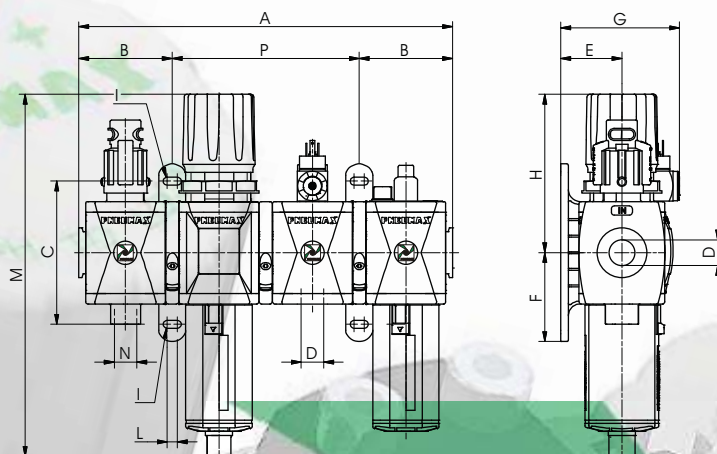
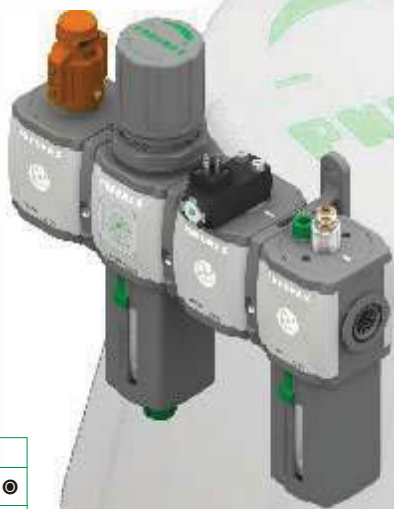

**Shut off valve, Filter-regulator,
Pressure switch, Lubricator**

Operational characteristic :
Combined group comprising manual shut off valve, filter-regulator with built in manometer, pressure switch and lubricator, assembled with two Y type coupling kits for panel mounting and one X type coupling kit.
Built in pressure gauge 0 to 12 bar range

Example : **GT171BVRG**
Size 1 Combined group G1/4" technopolymer connections comprising shut off valve, filter-regulator, pressure switch and lubricator 0 to 8 bar regulating range and 20 filtering element

NOTE: pressure gauge range 0 to 12 bar

	Size 1	Size 2	Size 3
A	192	248	292
B	48	62	73
C	80	95	110
D	G1/4"	G3/8"	G1/2"
E	30,5	40,5	44,5
F	47,5	59	66,5
G	62,5	79	83
H	81,5	105	112,5
I	Ø4,5	Ø5,2	Ø5,2
L	3	6,8	6,8
M	201,5	240,5	280
N	G1/4"	G3/8"	G3/8"
P	96	124	219

ORDERING CODE	
G	1710VRG
VERSION	
V	N = Metal insert T = Technopolymer thread
SIZE	
1	1 = Size 1 2 = Size 2 3 = Size 3
CONNECTIONS	
A	G = G1/8 - G1/4 - G3/8 (only for insert version)
B	G = G1/4 - G3/8 - G1/2
FILTER PORE SIZE ADJUSTING RANGE	
C	C = 5µ / 0-8 bar D = 5µ / 0-12 bar G = 20µ / 0-8 bar H = 20µ / 0-12 bar N = 50µ / 0-8 bar P = 50µ / 0-12 bar
OPTION	
	Standard
A	Min.oil level indicator NO
C	Min.oil level indicator NC
S	Automatic drain
SA	Automatic drain + min.oil level indicator NO
SC	Automatic drain + min.oil level indicator NC

Service unit assembled
(VL+EM+L+VE+AP)

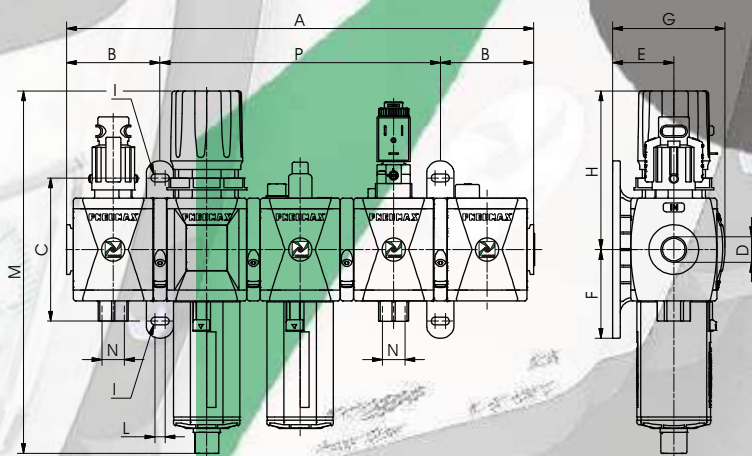

**Shut off valve, Filter-regulator, Lubricator,
Electric shut off valve, Progressive start up valve**

Operational characteristic :
Combined group comprising manual shut off valve, filter-regulator with built in manometer , lubricator, electric shut of valve and progressive start-up valve assembled with two Y type coupling kits for panel mounting and two X type coupling kits.

Built in pressure gauge 0 to 12 bar range

Example : **GT171BVHSGB9**
Size 1 Combined group G1/4" technopolymer connections comprising shut off valve, filter-regulator, Lubricator, electric shut off valve and progressive start up valve 0 to 8 bar regulating range and 20 filtering element

NOTE: pressure gauge range 0 to 12 bar

	Size 1	Size 2	Size 3
A	240	310	365
B	48	62	73
C	80	95	110
D	G1/4"	G3/8"	G1/2"
E	30,5	40,5	44,5
F	47,5	59	66,5
G	58	74,5	82,5
H	81,5	105	112,5
I	Ø4,5	Ø5,2	Ø5,2
L	3	6,8	6,8
M	201,5	240,5	280
N	G1/4"	G3/8"	G3/8"
P	144	186	219

ORDERING CODE	
G	1710VHSGA
VERSION	
V	N = Metal insert T = Technopolymer thread
SIZE	
1	1 = Size 1 2 = Size 2 3 = Size 3
CONNECTIONS	
A	G = G1/8 - G1/4 - G3/8 (only for insert version)
B	G = G1/4 - G3/8 - G1/2
FILTER PORE SIZE ADJUSTING RANGE	
C	C = 5µ / 0-8 bar D = 5µ / 0-12 bar G = 20µ / 0-8 bar H = 20µ / 0-12 bar N = 50µ / 0-8 bar P = 50µ / 0-12 bar
TENSION	
B2	Without coil M2 mechanic
B4	12 V DC
B5	24 V DC
B6	24 V AC (50-60 Hz)
B7	110 V AC (50-60 Hz)
B8	220 V AC (50-60 Hz)
B9	24 V DC (2 Watt)
OPTION	
	Standard
A	Min.oil level indicator NO
C	Min.oil level indicator NC
S	Automatic drain
SA	Automatic drain + min.oil level indicator NO
SC	Automatic drain + min.oil level indicator NC



New full range of air

Innovation

Con riserva di modifiche / Specifications may

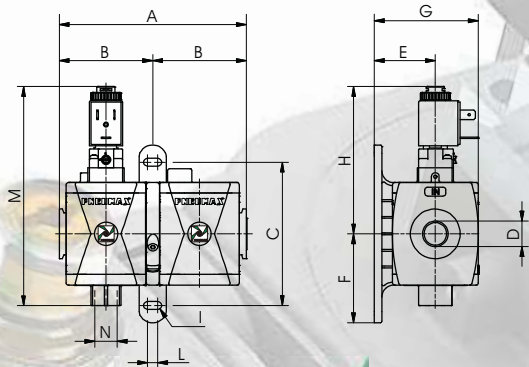

**Electric shut off valve,
Progressive start up valve**

Operational characteristic :
Combined group comprising electric shut off valve and progressive start up valve assembled with a Y type coupling kit for panel mounting.
Built in pressure gauge 0 to 12 bar range

	Size 1	Size 2	Size 3
A	96	124	146
B	48	62	73
C	80	95	110
D	G1/4"	G3/8"	G1/2"
E	30,5	40,5	44,5
F	47,5	59	66,5
G	51,5	69	77
H	88,5	97,5	101
I	Ø4,5	Ø5,2	Ø5,2
L	3	6,8	6,8
M	127	145,5	154,5
N	G1/4"	G3/8"	G3/8"

Example : GT171BSB2
Size 1 combined group comprising G1/4" technopolymer connections shut off valve, progressive start up valve, without coil with M2 pilot

ORDERING CODE

G V 17 T C S A

VERSION

- V = Metal insert
- T = Technopolymer thread

SIZE

- 1 = Size 1
- 2 = Size 2
- 3 = Size 3

CONNECTIONS

- C = A = G1/8 - G1/4 - G3/8 (only for insert versions)
- B = G1/4 - G3/8 - G1/2

TENSION

- B2 = Without coil
- M2 mechanic
- B4 = 12 V DC
- B5 = 24 V DC
- A = B6 = 24 V AC (50-60 Hz)
- B7 = 110 V AC (50-60 Hz)
- B8 = 220 V AC (50-60 Hz)
- B9 = 24 V DC (2 Watt)

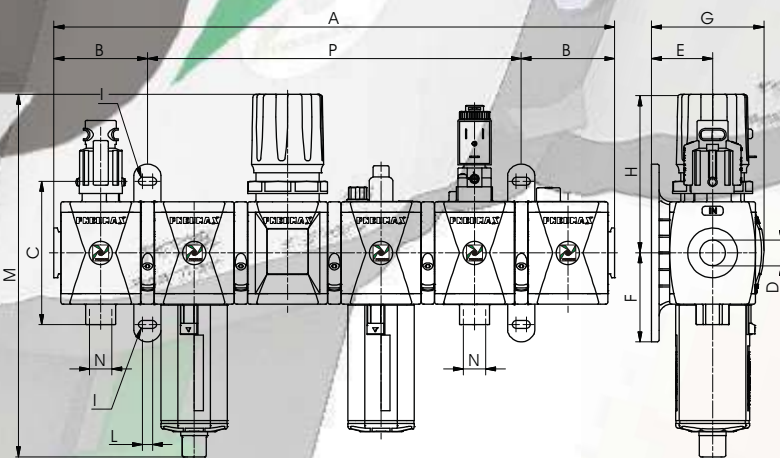

**Shut off valve, Filter, Regulator, Lubricator,
Electric shut off valve, Progressive start up valve**

Operational characteristic :
Combined group comprising manual shut off valve, filter, regulator with built in manometer , lubricator , electric shut of valve and progressive start up valve assembled with two Y type coupling kits for panel mounting and three X type coupling kits.
Built in pressure gauge 0 to 12 bar range

	Size 1	Size 2	Size 3
A	288	372	438
B	48	62	73
C	80	95	110
D	G1/4"	G3/8"	G1/2"
E	30,5	40,5	44,5
F	47,5	59	66,5
G	58	74,5	82,5
H	81,5	105	112,5
I	Ø4,5	Ø5,2	Ø5,2
L	3	6,8	6,8
M	201,5	240,5	280
N	G1/4"	G3/8"	G3/8"
P	192	248	292

Example : GT171BVKSGB9
Size 1 combined group G1/4" technopolymer connection comprising shut off valve, filter, regulator, lubricator, electrical shut of valve and progressive start up valve. 0 to 8 bar regulating range, 20 filtering element and 24V DC(2W) coil

NOTE: pressure gauge range 0 to 12 bar

ORDERING CODE

G V 17 T C V K S S A O

VERSION

- V = Metal insert
- T = Technopolymer thread

SIZE

- 1 = Size 1
- 2 = Size 2
- 3 = Size 3

CONNECTIONS

- C = A = G1/8 - G1/4 - G3/8 (only for insert versions)
- B = G1/4 - G3/8 - G1/2

FILTER PORE SIZE

ADJUSTING RANGE

- C = 5µ / 0-8 bar
- D = 5µ / 0-12 bar
- G = 20µ / 0-8 bar
- H = 20µ / 0-12 bar
- N = 50µ / 0-8 bar
- P = 50µ / 0-12 bar

TENSION

- B2 = Without coil
- M2 mechanic
- B4 = 12 V DC
- B5 = 24 V DC
- A = B6 = 24 V AC (50-60 Hz)
- B7 = 110 V AC (50-60 Hz)
- B8 = 220 V AC (50-60 Hz)
- B9 = 24 V DC (2 Watt)

OPTION

- Standard
- A = Min.oil level indicator NO
- C = Min.oil level indicator NC
- S = Automatic drain
- SA = Automatic drain + min.oil level indicator NO
- SC = Automatic drain + min.oil level indicator NC

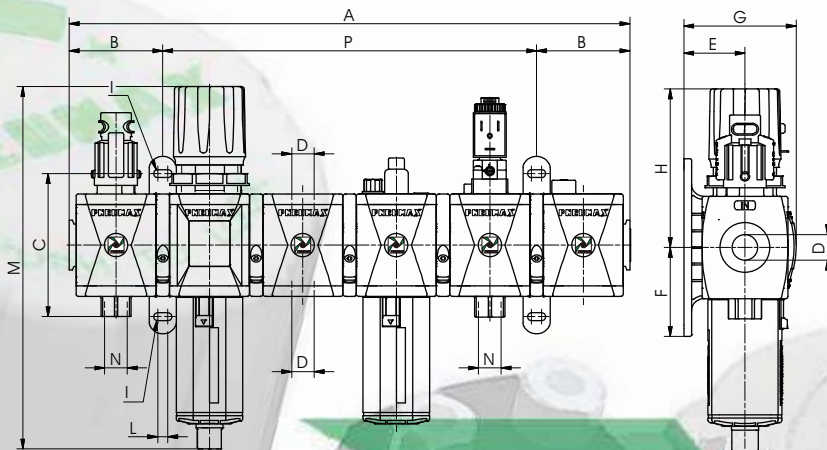
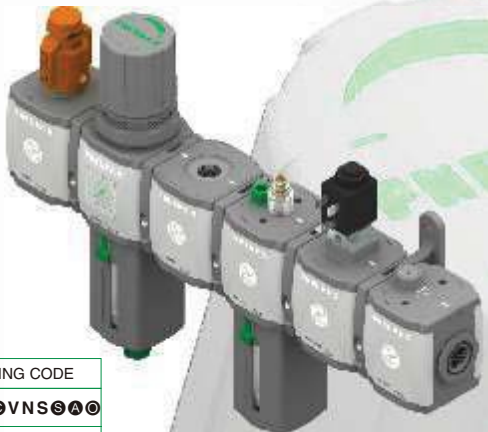

ORDERING CODE	
GV1710VNS6A0	
VERSION	
V	N = Metal insert
	T = Technopolymer thread
SIZE	
1	1 = Size 1
2	2 = Size 2
3	3 = Size 3
CONNECTIONS	
A	G 1/8 - G1/4 - G3/8 (only for insert version)
B	G1/4 - G3/8 - G1/2
FILTER PORE SIZE ADJUSTING RANGE	
C	5µ / 0-8 bar
D	5µ / 0-12 bar
G	20µ / 0-8 bar
H	20µ / 0-12 bar
N	50µ / 0-8 bar
P	50µ / 0-12 bar
TENSION	
B2	Without coil M2 mechanic
B4	12 V DC
B5	24 V DC
B6	24 V AC (50-60 Hz)
B7	110 V AC (50-60 Hz)
B8	220 V AC (50-60 Hz)
B9	24 V DC (2 Watt)
OPTION	
	Standard
A	Min.oil level indicator NO
C	Min.oil level indicator NC
S	Automatic drain
SA	Automatic drain + min.oil level indicator NO
SC	Automatic drain + min.oil level indicator NC

**Shut off valve, Filter-Regulator, Air intake,
Lubricator, Electric shut off valve, Progressive start up valve**

Operational characteristic :
Combined group comprising manual shut off valve, filter-regulator with built in manometer , air intake, lubricator , electric shut of valve and progressive start up valve assembled with two Y type coupling kits for panel mounting and three X type coupling kits.
Built in pressure gauge 0 to 12 bar range

Example : **GT171BVNSGB9**
Size 1 combined group G1/4" technopolymer connection comprising shut off valve, filter-regulator, air intake, lubricator, electrical shut of valve and progressive start up valve. 0 to 8 bar regulating range, 20 filtering element and 24V DC(2W) coil

NOTE: pressure gauge range 0 to 12 bar

	Size 1	Size 2	Size 3
A	288	372	438
B	48	62	73
C	80	95	110
D	G1/4"	G3/8"	G1/2"
E	30,5	40,5	44,5
F	47,5	59	66,5
G	58	74,5	82,5
H	81,5	105	112,5
I	Ø4,5	Ø5,2	Ø5,2
L	3	6,8	6,8
M	201,5	240,5	280
N	G1/4"	G3/8"	G3/8"
P	192	248	292

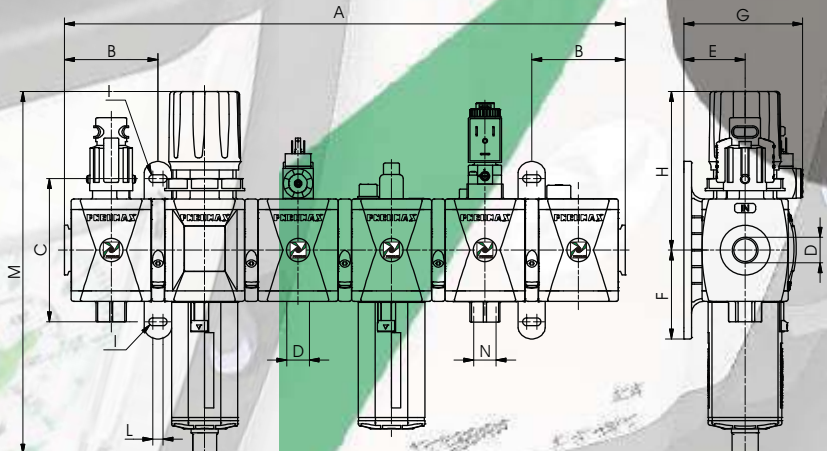
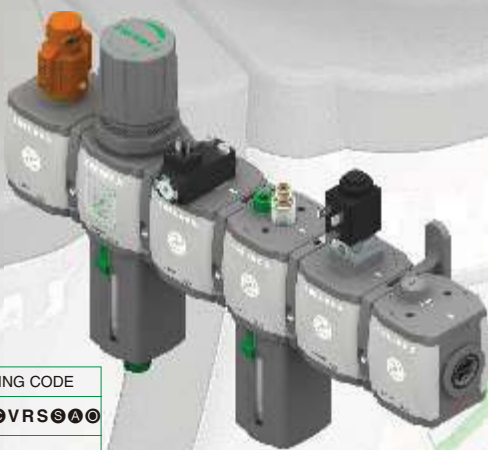

ORDERING CODE	
GV1710VRS6A0	
VERSION	
V	N = Metal insert
	T = Technopolymer thread
SIZE	
1	1 = Size 1
2	2 = Size 2
3	3 = Size 3
CONNECTIONS	
A	G 1/8 - G1/4 - G3/8 (only for insert version)
B	G1/4 - G3/8 - G1/2
FILTER PORE SIZE ADJUSTING RANGE	
C	5µ / 0-8 bar
D	5µ / 0-12 bar
G	20µ / 0-8 bar
H	20µ / 0-12 bar
N	50µ / 0-8 bar
P	50µ / 0-12 bar
TENSION	
B2	Without coil M2 mechanic
B4	12 V DC
B5	24 V DC
B6	24 V AC (50-60 Hz)
B7	110 V AC (50-60 Hz)
B8	220 V AC (50-60 Hz)
B9	24 V DC (2 Watt)
OPTION	
	Standard
A	Min.oil level indicator NO
C	Min.oil level indicator NC
S	Automatic drain
SA	Automatic drain + min.oil level indicator NO
SC	Automatic drain + min.oil level indicator NC

**Shut off valve, Filter-Regulator, Pressure switch, Lubricator,
Electric shut off valve, Progressive start up valve**

Operational characteristic :
Combined group comprising manual shut off valve, filter-regulator with built in manometer, Pressure switch, lubricator electric shut of valve and progressive start up valve assembled with two Y type coupling kits for panel mounting and three X type coupling kits.
Built in pressure gauge 0 to 12 bar range

Example : **GT171BVRSGB9**
Size 1 combined group G1/4" technopolymer connection comprising shut off valve, filter-regulator, Pressure switch, lubricator, electrical shut of valve and progressive start up valve. 0 to 8 bar regulating range, 20 filtering element and 24V DC(2W) coil

NOTE: pressure gauge range 0 to 12 bar

	Size 1	Size 2	Size 3
A	288	372	438
B	48	62	73
C	80	95	110
D	G1/4"	G3/8"	G1/2"
E	30,5	40,5	44,5
F	47,5	59	66,5
G	62,5	79	83
H	81,5	105	112,5
I	Ø4,5	Ø5,2	Ø5,2
L	3	6,8	6,8
M	201,5	240,5	280
N	G1/4"	G3/8"	G3/8"
P	192	248	292



New full range of air

Innovation

Con riserva di modifiche / Specifications may



D. DPL_016/GB - 09/2010
PRINTED IN ITALY - 09/2010

PNEUMAX S.p.A.
24050 LURANO (BG) - Italy
Via Cascina Barbellina, 10
Tel. 035/4192777
Fax 035/4192740
035/4192741
<http://www.pneumaxspa.com>
pneumax@pneumaxspa.com