



COMPRESSED AIR TREATMENT

Over 100,000 compressed air users expect more when it comes to their compressed air supply.

BOGE air provides them with the air to work.

If it is BOGE AIR then you can be assured that it is quality air “Made in Germany”. This not only applies to the first class energy efficient compressed air systems manufactured by BOGE but also to the top quality compressed air treatment products.

BOGE compressed air treatment products have been designed to work in perfect harmony with the compressor range to provide the optimal, most effective and efficient compressed air quality with options available to meet the highest air quality requirements.

CONTENTS

COMPRESSED AIR TREATMENT	4
DRYERS	8
FILTERS	20
CONVERTERS	26
COMPRESSED AIR STORAGE	29
CONDENSATE MANAGEMENT	30
BOGE SERVICE	34

Quality air pays off:

BOGE compressed air treatment

THE CLEAN UP! FROM AIR TO BOGE QUALITY AIR.

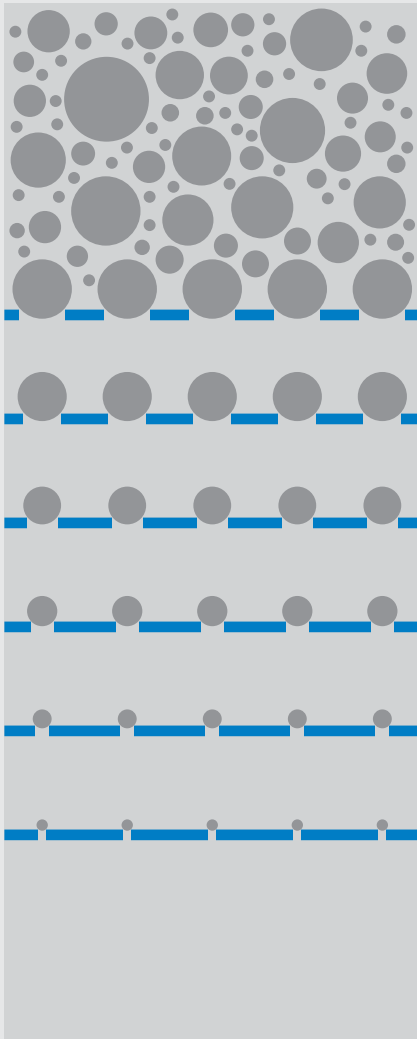

Compressed air is a versatile medium. It is widely used throughout Industry and, for example, can be found in workshops and garages where untreated air is acceptable or the specialist industries where the demanding environments of the pharmaceutical and food sectors require absolutely dry, oil-free and often sterile compressed air.

Compressed air users rely on quality air from BOGE wherever the safe and efficient purification of the compressed air is required. Our compressed air specialists will do their utmost to configure a customised air treatment system to meet any given set of criteria.

1 m³ of untreated ambient air can contain up to 180 million particles of dirt as well as 50 – 80% water vapour and oil in the form of unburned hydrocarbons. During the compression process the concentration of these particles increases: at a pressure of 10 bar, for example, an eleven-fold value of 2 billion dirt particles is reached. Optimally treated BOGE compressed air is dry, dust-free, oil-free and if required sterile.

Knowing the right answer: There are some industry sectors that cannot accept anything less than high quality compressed air. Such Industries can rely on BOGE to provide specialist professional advice in the selection of the correct air treatment system to suit their specific needs – and, to meet the required air quality in the most cost effective manner!

THE RIGHT BALANCE: ADVANTAGES OF BOGE COMPRESSED AIR TREATMENT.

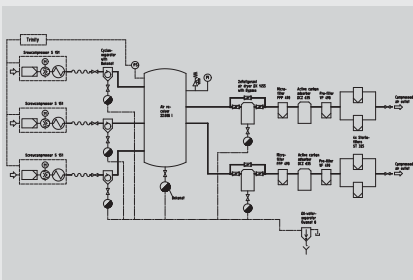

CAREFUL PLANNING AND ADVICE

When it comes to selecting the right type of air treatment, specialist advice is crucial because an incorrectly dimensioned system can easily generate unnecessary costs in the long run. You can count on the BOGE know-how: a thorough system analysis ensures that the installed air treatment exactly meets the site requirements.

OPTIMAL COST-BENEFIT RATIO

Compressed air treatment is a necessary cost in a compressed air system and so the chosen system should produce an optimal cost-benefit ratio. An oversized or undersized air treatment system is likely to result in unnecessary costs or jeopardise the operating integrity of the system. BOGE's range of air treatment products ensures that there is a cost effective customised solution for every application.

QUALITY "MADE IN GERMANY"

The use of high quality materials and a reduced number of wear parts ensures the BOGE air treatment systems are as efficient and reliable as our demanding customers rightfully expect. The BOGE manufacturing process also meets on-going quality standards – from inspection of purchased parts to final inspection and testing of each product. And, when it comes to product development, BOGE ranks among the first for German engineering: time after time we are recognised as trendsetters in the industry thanks to our innovations many of which have Worldwide patents.

From need to solution: System Planning with BOGE

Application for compressed air	Quality Class***			Air compressor
	Dust	Water	Oil	
<ul style="list-style-type: none"> • General industrial air • Blow-down air 	—	—	—	BOGE- SCREW OR PISTON COMPRESSOR
<ul style="list-style-type: none"> • Sandblasting • Simple painting work 	3	—	—	
<ul style="list-style-type: none"> • Conveying air • General factory air • High-quality sandblasting • Simple paint spraying 	3	4	5	
<ul style="list-style-type: none"> • Pneumatic tools • Control air • Paint spraying • Air Conditioning • Fluidics • Measuring and control systems 	1	4	1	
<ul style="list-style-type: none"> • Dental laboratory • Photographic laboratory 	1	4	1	
<ul style="list-style-type: none"> • Control air • Instrument air • Pneumatics • High-quality paint spraying • Surface finishing • Breathing air 	1	1-3	1	
<ul style="list-style-type: none"> • Medical system • Breathing air • High quality conveying air • Food industry 	1	3-4	1	
<ul style="list-style-type: none"> • Breweries • Dairies • Pharmaceutical industry 	1	1-3	1	

Cyclone-separator*	Pre-filter**	Refrigerant-dryer	Microfilter	Membrane dryer	Adsorption dryer	Pre-filter	Activated carbon filter	Activated carbon adsorber	Sterile filter
•	•								
•	•	•							
•	•	•	•						
•	•	•	•						
•	•	•	•						
•	•		•		•	•	•		
or									
•	•		•	•			•		
•	•	•	•				•	•	
or									
•	•		•	•			•		•
•	•		•	•		•	•	•	•
or									
•	•		•	•			•		•

* Only for compressors without compressed air receiver
 ** Coarser impurities separated out to extend service life of microfilter
 *** ISO 8573-1:1991

The right system for your requirements: Based on your air quality requirements BOGE will take care of selecting the appropriate air treatment products to provide an optimal solution from initial assessment to system design. You are invited to contact our experts for a consultation!

QUALITY CLASSES ACCORDING TO ISO 8573-1:2001

CLASS	Solid impurities (Max. particle size per m ³)				Humidity (Max. pressure dewpoint) °C	Max. oil content mg/m ³
	Max. particle size in µm					
	<= 0,1	0,1 < d <= 0,5	0,5 < d <= 1,0	1,0 < d <= 5,0		
0	as specified by user					
1	A/R	100	1	0	<= -70°C	<= 0,01 mg/m ³
2	A/R	100 000	1 000	10	<= -40°C	<= 0,1 mg/m ³
3	A/R	A/R	10 000	500	<= -20°C	<= 1 mg/m ³
4	A/R	A/R	A/R	1 000	<= +3°C	<= 5 mg/m ³
5	A/R	A/R	A/R	20 000	<= +7°C	—
6	—	—	—	—	<= +10°C	—

Classes 6 and 7 are defined according to the maximum particle size and maximum density.
 Class 6: $d \leq 5 \mu\text{m}$ and density $\leq 5 \text{ mg/m}^3$
 Class 7: $d \leq 40 \mu\text{m}$ and density $\leq 10 \text{ mg/m}^3$

Classes 7 to 9 are defined according to their liquid water content.
 Class 7: $C_w \leq 5 \text{ mg/m}^3$
 Class 8: $0,5 \text{ g/m}^3 < C_w \leq 5 \text{ mg/m}^3$
 Class 9: $5 \text{ g/m}^3 < C_w \leq 10 \text{ mg/m}^3$

BOGE COMPRESSED AIR DRYERS

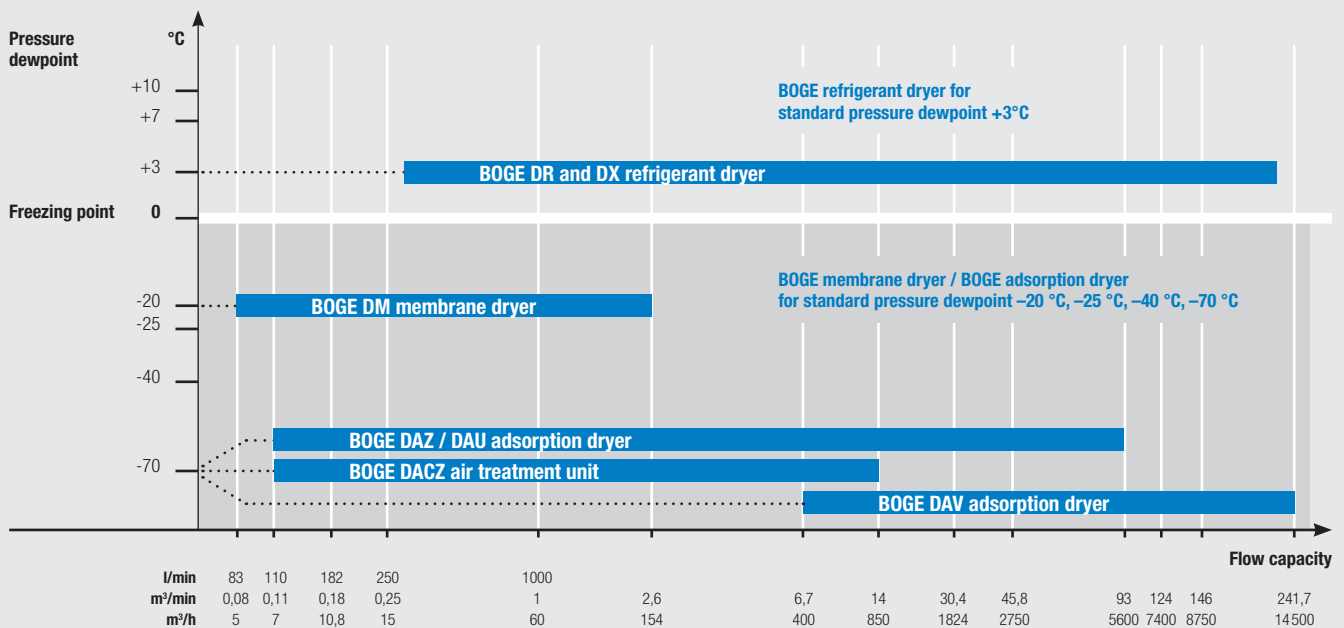

DR, DX = Refrigerant dryer
 DM = Membrane dryer
 DAZ = Adsorption dryer, heatless

DAV = Adsorption dryer, heat-regeneration with vacuum cooling
 DACZ = Air treatment unit comprising DAZ adsorption dryer, heatless with activated carbon adsorber

Compressed air refrigerant dryers

DR 3 to DR 275

Flow capacity: 0.33 – 27.5 m³/min, 12 – 972 cfm

Max. operating pressure: 16 bar, 235 psig

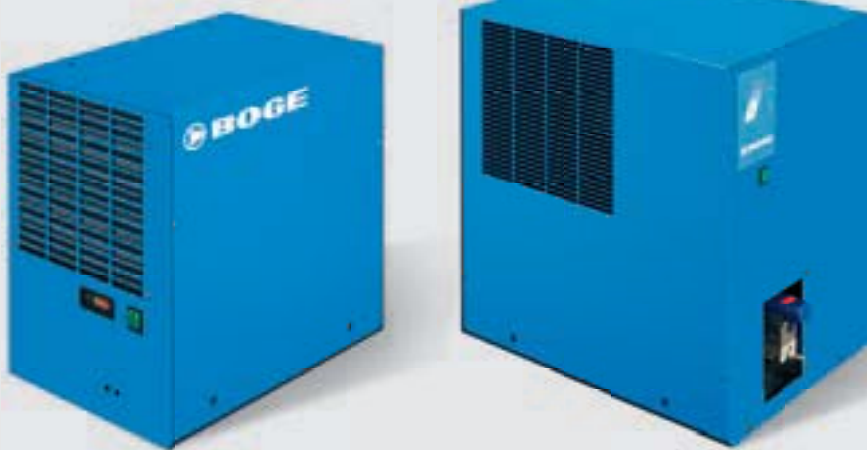

RELIABLE PRESSURE DEW POINT +3°C

The BOGE refrigerant dryer is designed to maintain a constant pressure dew point of +3°C, providing a consistently high compressed air quality, with a low pressure differential. A low pressure differential means a lower generation pressure which saves money! The DR series dryers are equipped with a pressure dew point indicator.

ELECTRONIC LEVEL CONTROLLED CONDENSATE DRAIN

A loss free BOGE Bekomat condensate drain is fitted as standard. This significantly contributes to the efficient and reliable operation of the refrigerant dryer.

EFFICIENCY

The BOGE dryer control is microprocessor based which saves energy when handling variable volumes of air. Above model DR 25 an additional control switches off the dryer during periods of standstill saving up to 90% of the dryer energy costs.

ENVIRONMENTALLY FRIENDLY COOLANT

The R 134a coolant is used throughout the entire DR series. The BOGE system requires minimum quantities of this ozone friendly coolant – up to 70% less than in conventional designs.

Installation requirements

The dryer is designed for maximum ambients of +50 °C and a minimum +2 °C. Sufficient clearance must be provided on all sides of the dryer to ensure good cooling air circulation. A suitably dimensioned drainage pipe must be installed to remove condensate.

Installation data

Flow capacity is based on the compressor's air intake (+20°C and 1 bar): Compressed air temperature +35°C (max. +65°C or +70°C possible), operating pressure 7 bar, ambient temperature +25°C (max. +50°C possible), pressure dew point +3°C (different pressure dew points are possible). Technical data according to DIN ISO 7183. Differing values on request.

Equipment:

- Illuminated operating switch
- Heat exchanger with demister
- Wall mounting possible up to DR 21
- Power plug up to DR 75
- Terminal box from DR 91
- Emergency stop switch from DR 91

Options:

- Standard bypass assembly
- Potential-free error message, Status message and Remote On/Off
- Special voltages
- Water-cooled option from DR 180
- Internal frost protection (to -10°C) from DR 25

The most efficient method of drying compressed air: Compressed air is cooled to just above freezing point which means that water and oil aerosols contained in the air will condense. During this process the aerosols tend to bind up and also discharge the dirt particles. An amply sized heat exchanger ensures reliability even in temporary extreme conditions. Maximum efficiency and operational reliability can therefore be expected from the BOGE DR series.

BOGE Type	Flow capacity			max. pressure bar	Pressure differential at full load		Electr. power consumption		Electr. power supply V/Hz		Compressed air connection	Cooling air required		Dimensions W x D x H (mm)		Weight kg
	m³/min	m³/h	cfm		bar	bar	psig	kW	HP	50 Hz		60 Hz	m³/h	cfm	mm	
DR 3	0,33	20	12	16	0,06	0,9	0,15	0,20	230	230	G 1/2	380	224	310x450x 450	25	
DR 6	0,58	35	21	16	0,15	2,1	0,16	0,22	230	230	G 1/2	380	224	310x450x 450	26	
DR 8	0,83	50	29	16	0,19	2,7	0,22	0,30	230	230	G 1/2	320	188	310x450x 450	27	
DR 11	1,08	65	38	16	0,22	3,1	0,24	0,33	230	230	G 1/2	320	188	310x450x 450	28	
DR 17	1,75	105	62	16	0,22	3,1	0,35	0,48	230	230	G 1/2	260	153	310x450x 450	31	
DR 21	2,08	125	74	16	0,28	4,0	0,44	0,60	230	230	G 1/2	260	153	310x450x 450	32	
DR 25	2,50	150	88	14	0,28	4,0	0,45	0,61	230	–	G 1	650	383	500x710x 740	59	
DR 30	3,00	180	106	14	0,14	2,0	0,56	0,76	230	–	G 1 1/2	650	383	500x710x 740	60	
DR 50	5,00	300	177	14	0,28	4,0	0,90	1,22	230	–	G 1 1/2	1300	765	500x710x 740	79	
DR 60	6,00	360	212	14	0,16	2,3	0,95	1,29	230	–	G 1 1/2	1300	765	500x710x 740	80	
DR 75	7,50	450	265	14	0,24	3,4	1,08	1,47	230	–	G 1 1/2	900	530	500x710x 740	85	
DR 91	9,17	550	324	14	0,18	2,6	1,25	1,70	400	–	G 2	2700	1589	500x850x 970	90	
DR 108	10,83	650	383	14	0,24	3,4	1,30	1,77	400	–	G 2	2700	1589	500x850x 970	92	
DR 125	12,50	750	442	14	0,19	2,7	1,50	2,04	400	–	G 2	2700	1589	500x850x 970	117	
DR 141	14,16	850	501	14	0,18	2,6	1,77	2,41	400	–	G 2	2700	1589	500x850x 970	121	
DR 180	17,75	1065	627	16	0,30	4,3	2,56	3,48	400	–	G 2 1/2	3100	1825	900x800x1230	176	
DR 190	18,50	1110	654	16	0,28	4,0	2,80	3,81	400	–	G 2 1/2	2600	1530	900x800x1230	181	
DR 225	22,50	1350	795	16	0,16	2,3	2,95	4,01	400	–	G 2 1/2	2600	1530	900x800x1230	186	
DR 235	23,50	1410	830	16	0,19	2,7	3,10	4,22	400	–	G 2 1/2	2600	1530	900x800x1230	191	
DR 275	27,50	1650	972	16	0,31	4,4	3,25	4,42	400	–	G 2 1/2	2600	1530	900x800x1230	197	

Conversion factors

According to DIN ISO 7183, refrigerant dryers are designed for 7 bar operating pressure, an ambient temperature of 25 °C and an inlet temperature of 35 °C. For different operating pressures and temperatures, the following conversion factors should be used.

Ambient/cooling water temperature	°C	25	30	35	40	45	50									
Factor	f ₁	1,00	0,97	0,94	0,87	0,75	0,62									
Inlet temperature	°C	30	35	40	45	50	55	60	65	70						
Factor	f ₂	1,28	1,00	0,88	0,75	0,58	0,48	0,44	0,42	0,40						
Operating pressure	bar	2	3	4	5	6	7	8	9	10	11	12	13	14	15	16
Factor	f ₃	0,60	0,70	0,80	0,88	0,94	1,00	1,04	1,06	1,09	1,10	1,12	1,14	1,15	1,16	1,17

Example (for dewpoint 3°C)

Delivery volume	m³/h	750	Factor				
Ambient temperature (f ₁)	°C	40	=	0,87	$= \frac{V}{f_1 \times f_2 \times f_3} = \frac{750}{0,87 \times 0,75 \times 1,14} = 1008 \quad \text{DR 180}$		
Inlet temperature (f ₂)	°C	45	=	0,75			
Operating overpressure (f ₃)	bar	13	=	1,14			

Refrigerant dryers **DX 300** to **DX 2375**

Flow capacity: 30 – 237.5 m³/min, 1059 – 8379 cfm

Max. operating pressure: 16 bar, 235 psig



RELIABLE – PRESSURE DEW POINT +3°C

The pressure dew point display can be changed between normal, summer, and automatic. The refrigerant dryer provides a consistently high quality compressed air.

EFFECTIVE CONTROL

The refrigerant dryer is equipped with a CAN-BUS interface and allows potential-free communication of operating and DTP failures. The back-lit control display shows all essential operating parameters.

INTELLIGENT REGULATION

The entire series allows for load dependent control for optimal energy efficiency: DX 300 up to DX 915 have a suction pressure regulation whilst the DX 580 up to DX 2375 are equipped with frequency control.

ENVIRONMENTALLY FRIENDLY COOLANT

The R 134a coolant is used throughout the entire series. The BOGE system requires minimum quantities of this ozone friendly coolant – up to 70% less than in conventional designs.

Installation requirements

The dryer is designed for maximum ambients of +50 °C and a minimum +2 °C. Sufficient clearance must be provided on all sides of the dryer to ensure good cooling air circulation. A suitably dimensioned drainage pipe must be installed to remove condensate.

Explanations / Installation data

Flow capacity is based on the compressor's air intake (+20°C and 1 bar): Compressed air temperature +35°C (max. +65°C or +70°C possible), operating pressure 7 bar, ambient temperature +25°C (max. +50°C possible), pressure dew point +3°C (different pressure dew points are possible). Technical data according to DIN ISO 7183.

Options:

- Standard bypass assembly
- Water-cooled version up to DX 915
- Air-cooled version from DX 1156
- Internal frost protection (to -10°C)

Compressed air drying can be extremely cost effective: Due to its efficient and cost effective control the DX series provides absolutely energy efficient compressed air drying. The energy consumption display illustrates the large savings potential by ensuring dry compressed air is produced in the most energy efficient manner.

BOGE Type	Flow capacity			Pressure differential at full load		Electr. power consumption			Electr. power supply V/50 Hz	Compressed air connection (DIN 2633)	Cooling air required at aircooling		Cooling air required at watercooling		Dimensions W x D x H		Weight kg
	m³/min	m³/h	cfm	bar	psig	100% full load kW	50% part load kW	0% off load kW			m³/h	cfm	m³/h	cfm	mm		
DX 300	30,0	1800	1059	0,12	1,74	3,1	1,7	0,4	400	DN 100	4800	2823	1,0	0,588	900 x 1175 x 1725		412
DX 330	33,3	2000	1176	0,14	2,03	3,2	1,9	0,4	400	DN 100	4800	2823	1,1	0,647	900 x 1175 x 1725		420
DX 380	38,3	2300	1353	0,19	2,76	3,4	2,0	0,4	400	DN 100	4800	2823	1,3	0,765	900 x 1175 x 1725		425
DX 465	46,6	2800	1647	0,24	3,48	3,9	2,3	0,5	400	DN 100	5200	3058	1,6	0,941	900 x 1175 x 1725		435
DX 580	58,3	3500	2058	0,11	1,60	5,9	3,4	0,7	400	DN 150	9600	5645	2,0	1,176	1200 x 1200 x 1940		610
DX 715	71,6	4300	2529	0,16	2,32	6,6	3,8	0,8	400	DN 150	9600	5645	2,5	1,470	1200 x 1200 x 1940		630
DX 915	91,6	5500	3234	0,24	3,48	8,0	4,6	1,0	400	DN 150	10400	6115	2,9	1,710	1200 x 1200 x 1940		670
DX 1165	116,7	7000	4116	0,19	2,76	9,9	5,6	1,2	400	DN 200	19200	11290	4,0	2,350	2225 x 1200 x 1970		995
DX 1455	145,8	8750	5145	0,17	2,47	12,4	7,0	1,6	400	DN 200	19200	11290	5,2	3,060	2225 x 1200 x 1970		1165
DX 1750	175,0	10500	6174	0,22	3,19	14,6	8,2	1,8	400	DN 200	20800	12231	6,4	3,760	2225 x 1200 x 1970		1225
DX 2080	208,3	12500	7350	0,22	3,19	18,6	10,3	2,3	400	DN 250	23000	13524	7,5	4,410	3345 x 1200 x 2030		1710
DX 2375	237,5	14250	8379	0,20	2,90	20,2	11,2	2,5	400	DN 250	23000	13524	8,5	5,000	3345 x 1200 x 2030		1940

Conversion factors

According to DIN ISO 7183, refrigerant dryers are designed for 7 bar operating pressure, an ambient temperature of 25 °C and an inlet temperature of 35 °C. For different operating pressures and temperatures, the following conversion factors should be used.

Ambient/cooling water temperature	°C	25	30	35	40	45	50									
Factor	f ₁	1,00	0,98	0,93	0,84	0,72	0,56									
Inlet temperature	°C	30	35	40	45	50	55	60	65	70						
Factor	f ₂	1,20	1,00	0,82	0,67	0,55	0,45	0,38	0,34	0,30						
Operating pressure	bar	2	3	4	5	6	7	8	9	10	11	12	13	14	15	16
Factor	f ₃	0,60	0,70	0,80	0,88	0,94	1,00	1,04	1,06	1,09	1,10	1,12	1,14	1,15	1,16	1,17

Example (for dewpoint 3°C)

Delivery volume	m³/h	3500	Factor		
Ambient temperature (f ₁)	°C	40	=	0,84	
Inlet temperature (f ₂)	°C	50	=	0,55	
Operating overpressure (f ₃)	bar	10	=	1,09	

$$= \frac{V}{f_1 \times f_2 \times f_3} = \frac{3500}{0,84 \times 0,55 \times 1,09} = 6950 \quad \text{DX 1165}$$

Membrane dryers

DM 05 V to DM 14 V

Flow capacity: 125 – 2730 l/min, 4 – 96 cfm

Max. operating pressure: 7 – 15 bar, 100 – 220 psig



INTEGRATED CYCLONE SEPARATOR

An integrated cyclone separator assures optimal functioning of the membrane dryer by way of pre-filtration.

ENERGY EFFICIENT

As the membrane dryer does not have a motor or any moving parts it does not need any additional energy eliminating unnecessary energy costs.

INTEGRATED COMPRESSED AIR FILTER

A standard compressed air filter is included to provide technically oil free compressed air.

ENVIRONMENTALLY FRIENDLY

The membrane dryer does not contain any CFCs and is therefore neither ozone depleting nor does it have any impact on the environment.

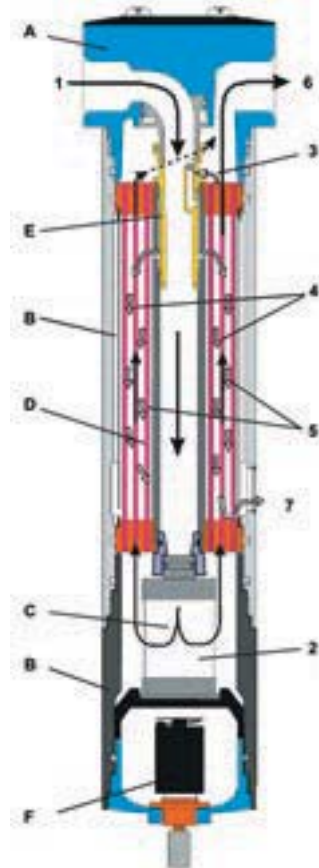

Membrane Dryer Layout

A: Head (inlet / outlet)

B: Filter housing

C: Nano-filter

D: Membrane element including main body

E: Nozzle with adapter

F: Float drain

(1) Saturated compressed air enters via the dryer cap (A) and flows down the central tube (D). **(2)** The Nano-filter (C) removes any remaining aerosols and particles, separated condensate is drained (F). The saturated compressed air flows through the inside of the membranes. **(3)** A part of the compressed air is diverted and expands to atmosphere at the nozzle (E). **(4)** This very dry purge air is lead across the outside of the membranes (D). **(5)** Thus the saturated compressed air flows on the inside and the dry purge air on the outside. Due to the differences in humidity, moisture diffuses from the compressed air to the purge air. **(6)** The dry compressed air exits. **(7)** The purge air escapes to the atmosphere.

Pressure dew point reduction in a compact package: The BOGE membrane dryer is used where the pressure dew point needs to be reduced between +20 and +55°C. It requires little space and can be installed at minimal cost – ideally between the compressor and the receiver.

BOGE Type	Max. operating pressure		Flow volume Dryer inlet		Purge air			Flow volume Dryer outlet		Compressed air connection IN/OUT	Dimensions L x W x H mm	Weight kg
	bar	psig	l/min	cfm	Δt	l/min	cfm	l/min (air used)	cfm			
DM 05 V	7	100	300	11	20 K	30	1	270	10	G 3/8	167 x 60 x 522	3,0
DM 05 V	9	130	420	15	20 K	38	1	382	13	G 3/8	167 x 60 x 522	3,0
DM 05 V	15	220	750	26	20 K	62	2	688	24	G 3/8	167 x 60 x 522	3,0
DM 05 V	7	100	180	6	35 K	30	1	150	5	G 3/8	167 x 60 x 522	3,0
DM 05 V	9	130	250	9	35 K	38	1	212	7	G 3/8	167 x 60 x 522	3,0
DM 05 V	15	220	460	16	35 K	62	2	398	14	G 3/8	167 x 60 x 522	3,0
DM 05 V	7	100	125	4	55 K	30	1	95	3	G 3/8	167 x 60 x 522	3,0
DM 05 V	9	130	175	7	55 K	38	1	137	5	G 3/8	167 x 60 x 522	3,0
DM 05 V	15	220	320	11	55 K	62	2	258	9	G 3/8	167 x 60 x 522	3,0
DM 06 V	7	100	400	14	20 K	40	1	360	13	G 3/8	167 x 60 x 582	3,2
DM 06 V	9	130	560	20	20 K	50	2	510	18	G 3/8	167 x 60 x 582	3,2
DM 06 V	15	220	950	34	20 K	80	3	870	31	G 3/8	167 x 60 x 582	3,2
DM 06 V	7	100	240	8	35 K	40	1	200	7	G 3/8	167 x 60 x 582	3,2
DM 06 V	9	130	335	12	35 K	50	2	285	10	G 3/8	167 x 60 x 582	3,2
DM 06 V	15	220	605	21	35 K	80	3	525	19	G 3/8	167 x 60 x 582	3,2
DM 06 V	7	100	170	6	55 K	40	1	130	5	G 3/8	167 x 60 x 582	3,2
DM 06 V	9	130	235	8	55 K	50	2	185	7	G 3/8	167 x 60 x 582	3,2
DM 06 V	15	220	425	15	55 K	80	3	345	12	G 3/8	167 x 60 x 582	3,2
DM 09 V	7	100	600	21	20 K	60	2	540	19	G 3/4	210 x 80 x 592	4,5
DM 09 V	9	130	835	29	20 K	75	3	760	27	G 3/4	210 x 80 x 592	4,5
DM 09 V	15	220	1470	52	20 K	125	4	1345	47	G 3/4	210 x 80 x 592	4,5
DM 09 V	7	100	360	13	35 K	60	2	300	11	G 3/4	210 x 80 x 592	4,5
DM 09 V	9	130	505	18	35 K	75	3	430	15	G 3/4	210 x 80 x 592	4,5
DM 09 V	15	220	890	31	35 K	125	4	765	27	G 3/4	210 x 80 x 592	4,5
DM 09 V	7	100	245	9	55 K	60	2	185	7	G 3/4	210 x 80 x 592	4,5
DM 09 V	9	130	345	12	55 K	75	7	270	10	G 3/4	210 x 80 x 592	4,5
DM 09 V	15	220	650	23	55 K	125	4	525	19	G 3/4	210 x 80 x 592	4,5
DM 13 V	7	100	800	28	20 K	80	3	720	25	G 3/4	210 x 80 x 642	4,8
DM 13 V	9	130	1110	39	20 K	105	4	1005	35	G 3/4	210 x 80 x 642	4,8
DM 13 V	15	220	1820	64	20 K	155	5	1665	59	G 3/4	210 x 80 x 642	4,8
DM 13 V	7	100	485	17	35 K	80	3	405	14	G 3/4	210 x 80 x 642	4,8
DM 13 V	9	130	675	24	35 K	105	4	570	20	G 3/4	210 x 80 x 642	4,8
DM 13 V	15	220	1150	41	35 K	155	5	995	35	G 3/4	210 x 80 x 642	4,8
DM 13 V	7	100	330	12	55 K	80	3	250	9	G 3/4	210 x 80 x 642	4,8
DM 13 V	9	130	465	16	55 K	105	4	360	13	G 3/4	210 x 80 x 642	4,8
DM 13 V	15	220	820	29	55 K	155	5	665	23	G 3/4	210 x 80 x 642	4,8
DM 14 V	7	100	1050	37	20 K	120	4	930	33	G 3/4	210 x 80 x 712	5,1
DM 14 V	9	130	1470	52	20 K	150	5	1320	47	G 3/4	210 x 80 x 712	5,1
DM 14 V	15	220	2730	96	20 K	250	9	2480	88	G 3/4	210 x 80 x 712	5,1
DM 14 V	7	100	710	25	35 K	120	4	590	21	G 3/4	210 x 80 x 712	5,1
DM 14 V	9	130	990	35	35 K	150	5	840	30	G 3/4	210 x 80 x 712	5,1
DM 14 V	15	220	1780	63	35 K	250	9	1530	54	G 3/4	210 x 80 x 712	5,1
DM 14 V	7	100	485	17	55 K	120	4	365	13	G 3/4	210 x 80 x 712	5,1
DM 14 V	9	130	680	24	55 K	150	5	530	19	G 3/4	210 x 80 x 712	5,1
DM 14 V	15	220	1320	47	55 K	250	9	1070	38	G 3/4	210 x 80 x 712	5,1

Adsorption dryers **DAZ 4 to DAZ 1021**

Adsorption dryer units **DACZ 4 to DACZ 161**

Flow capacity: 8 – 6100 m³/h, 5 – 3587 cfm

Max. operating pressure: 10 bar and 16 bar, 150 and 230 psig



Adsorption dryer **DAZ**

heatless with pre- and after-filters

MICROPROCESSOR CONTROL

The microprocessor control enables energy efficient control of the adsorption dryer. Optional dew point control reduces the regeneration air volume depending on temperature, pressure and output quantity.

FUNCTION DISPLAY

A functional display at the front of the control cabinet permanently indicates operational status. The ten-minute cycle can save up to six percent of energy. The compressor synchronising control can also offer further energy savings potential.



Treatment system **DACZ series**

The **DAZ** Adsorption Dryer combined with a **(C)** Activated Carbon Adsorber.

FILTRATION

The entire range is equipped with both pre and after filter as standard. Even before drying, all solids and aerosols up to 0.01 µm are removed from the compressed air supply – assuring best possible quality.

LOW RESIDUAL OIL CONTENT

The DACZ series is equipped with an activated carbon adsorber to ensure a residual oil content of only 0.003 mg/m³ – for the highest quality compressed air.

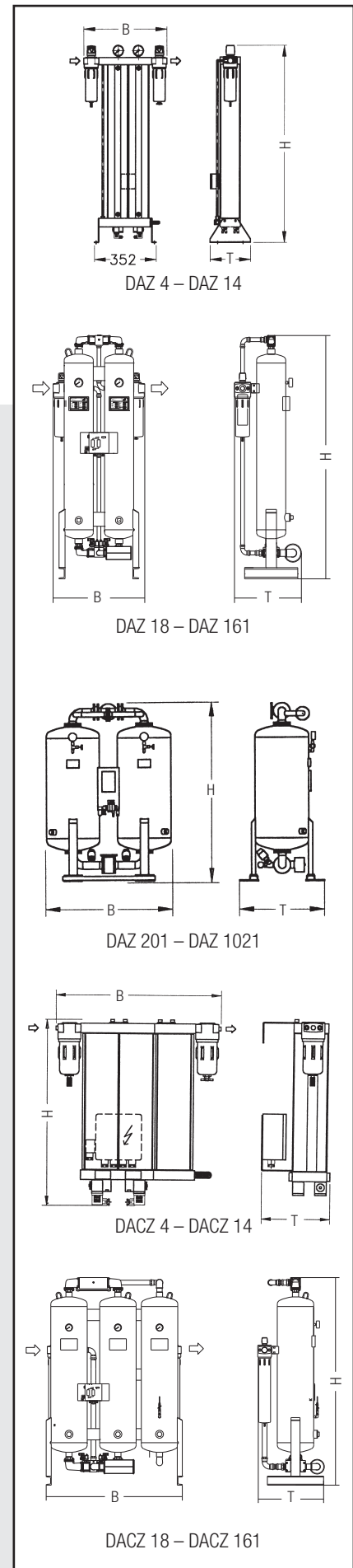

The all-in one package for dry compressed air: The ideal solution for compressed air pressure dew points below +3°C. The heatless BOGE adsorption dryers can reach dew points of -70°C (standard -40°C).

The twin tower system allows regeneration simultaneously with the adsorption eliminating the need for any external power supply.

BOGE Type	Capacity*		Dimensions W/D/H mm	Con-nection	Weight kg**	BOGE Type	Capacity*		Dimensions W/D/H mm	Con-nection	Weight kg
	m³/h	cfm					m³/h	cfm			
DAZ 4	8	5	312x 210x 390	G 1/4	9	DACZ 4	8	5	445x210x 390	G 1/4	12
DAZ 5	15	9	312x 210x 565	G 1/4	13	DACZ 5	15	9	445x210x 565	G 1/4	17
DAZ 6	25	15	359x 210x 815	G 1/4	17	DACZ 6	25	15	492x210x 815	G 1/4	24
DAZ 8	35	21	359x 210x1065	G 1/4	25	DACZ 8	35	21	492x210x1065	G 1/4	34
DAZ 9	56	33	436x 300x1185	G 3/8	52	DACZ 9	56	33	629x300x1185	G 3/8	72
DAZ 11	72	42	436x 300x1410	G 3/8	65	DACZ 11	72	42	629x300x1410	G 3/8	90
DAZ 14	86	50	436x 300x1610	G 1/2	77	DACZ 14	86	50	629x300x1610	G 1/2	107
DAZ 18	105	62	670x 510x1445	G 1	125	DACZ 18	105	62	870x510x1445	G 1	158
DAZ 26	145	85	670x 515x1690	G 1	143	DACZ 26	145	85	870x515x1690	G 1	183
DAZ 36	200	118	670x 530x1710	G 1	178	DACZ 36	200	118	1010x530x1710	G 1	235
DAZ 46	255	150	710x 535x1770	G 1	218	DACZ 46	255	150	1075x535x1770	G 1	295
DAZ 61	350	206	841x 570x1790	G 1 1/2	252	DACZ 61	350	206	1096x570x1790	G 1 1/2	340
DAZ 71	420	247	841x 570x1815	G 1 1/2	286	DACZ 70	420	247	1145x570x1815	G 1 1/2	390
DAZ 101	620	365	841x 590x1845	G 1 1/2	375	DACZ 101	620	365	1295x590x1845	G 1 1/2	525
DAZ 126	750	441	1010x 610x1980	G 2	430	DACZ 126	750	441	1610x610x1980	G 2	570
DAZ 161	940	553	1010x 630x2000	G 2	505	DACZ 161	940	553	1650x630x2000	G 2	685
DAZ 201	1200	706	1060x 840x2080	DN 50	640						
DAZ 261	1550	912	1270x 900x2120	DN 65	830						
DAZ 341	2000	1176	1350x 990x2160	DN 65	955						
DAZ 421	2500	1470	1530x1040x2210	DN 80	1075						
DAZ 501	3000	1764	1600x1100x2255	DN 80	1500						
DAZ 646	3800	2235	1875x1200x2385	DN 100	1990						
DAZ 811	4850	2852	1925x1250x2660	DN 100	2410						
DAZ 1021	6100	3587	2160x1565x2820	DN 125	2850						

Upon request

* Capacity in m³/h at 1 bar to DIN ISO 7183 ** from DAZ 200 weight without filter
 Max. operating pressure DAZ 4 – DAZ 160 **16 bar**
 DAZ 200 – DA 1020 **10 bar**
 Electrical connection 230V; 50 Hz; 0,021 kW
 (Dimensions and weights for models DA/DAC 200 onwards do not include pre-filters and after filters)

Conversion factors to determine dryer size for PDP to -40 °C

Temperature	Pressure bar (g)											
	5	6	7	8	9	10	11	12	13	14	15	16
35°C	0,75	0,89	1,00	1,08	1,26	1,31	1,36	1,49	1,62	1,70	1,79	1,90
40°C	0,64	0,78	0,91	1,00	1,08	1,16	1,24	1,35	1,47	1,57	1,67	1,77
45°C	0,61	0,73	0,82	0,94	1,03	1,07	1,10	1,22	1,35	1,46	1,57	1,66
50°C	0,59	0,67	0,79	0,86	0,99	1,03	1,07	1,18	1,29	1,37	1,46	1,55

Higher inlet temperatures available upon request. Subject to modification.

Example: Compressed air to be dried

	a) To calculate the specific dryer capacity		b) To calculate the max. dryer capacity
Volume flow	375 m³/h		Nominal capacity x factor from table
Min. operating pressure	8 bar (ü)	$\frac{\text{eff. capacity}}{\text{factor from table}} = \frac{375 \text{ m}^3/\text{h}}{1.08} = 347 \text{ m}^3/\text{h}$	(DAZ 61) = 350 m³/h x 1.08 = 378 m³/h
Max. inlet temperature	+35°C		
Pressure dew point	-40°C		
Factor from table	1.08	Selected type DAZ 61.	

Heatless adsorption dryer

DAU 1 N to DAU 17 N

Flow capacity: 5 – 100 m³/h, 3 – 60 cfm

Max. operating pressure: 16 bar

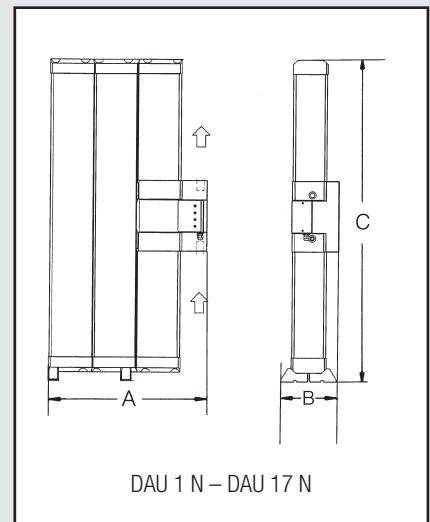

INLET AND OUTLET VALVES

The generously dimensioned inlet and outlet valves ensure a lower pressure differential across the dryer. Energy savings are therefore possible due to tighter operating pressure band.

REGENERATION

The twin tower system allows regeneration simultaneously with the adsorption eliminating the need for any external power supply. The wet tower is purged via a stream of dry air that is finally vented to atmosphere.

FILTRATION

The entire range is equipped with both pre and after filter as standard. Even before drying, all solids and aerosols up to 0.01 µm are removed from the compressed air supply – assuring best possible quality.

DEW POINT CONTROL

The entire series is available with dew point control that minimises the regeneration air volume depending on temperature, pressure and output quantity thus reducing operating costs.

The easy way to dry compressed air: The standard BOGE adsorption dryers achieve a pressure dew point of -40°C . They can be configured to reach -70°C . Such dewpoints eliminate the risk of downstream condensate especially in the case of an external airline. Adsorption dryers do not contain any CFCs and are therefore neither ozone depleting nor do they have any impact on the environment.

BOGE Type	Capacity*		Regeneration Air (1 bar, +20°C)		Air Outlet (minimal) (1 bar, +20°C)		Pressure Loss New Condition mbar	Dimensions A x B x C mm	Con-nection	Weight kg
	m ³ /h	cfm	m ³ /h	cfm	m ³ /h	cfm				
DAU 1 N	5	3	0,85	0,5	4,1	2,4	65	300x121x 343	G ½	7
DAU 2 N	10	6	1,70	1,0	8,1	4,8	95	300x121x 591	G ½	11
DAU 3 N	15	9	2,55	1,5	12,2	7,2	115	300x121x 853	G ½	15
DAU 5 N	25	15	4,25	2,5	20,3	11,9	250	300x121x1377	G ½	24
DAU 6 N	35	20	5,95	3,5	28,4	16,7	75	531x195x 665	G1	29
DAU 8 N	50	30	8,50	5,0	40,6	23,9	100	531x195x 917	G1	38
DAU 11 N	65	40	11,10	6,5	52,8	31,1	125	531x195x1169	G1	48
DAU 13 N	80	45	13,60	8,0	65,0	38,2	170	531x195x1421	G1	57
DAU 17 N	100	60	17,00	10,0	61,3	36,0	250	531x195x1673	G1	67

*Capacity relative to 1 bar according to DIN ISO 7183

Design: DAU 1 N – DAU 17 N, Correction factor f

Temperature	Operating pressure bar (g)												
	4	5	6	7	8	9	10	11	12	13	14	15	16
25°C	0,69	0,82	0,96	1,10	1,24	1,38	1,50	1,50	1,50	1,50	1,50	1,50	1,50
30°C	0,69	0,82	0,96	1,10	1,24	1,38	1,50	1,50	1,50	1,50	1,50	1,50	1,50
35°C	0,63	0,75	0,88	1,00	1,13	1,26	1,38	1,50	1,50	1,50	1,50	1,50	1,50
40°C	0,48	0,58	0,68	0,77	0,87	0,96	1,06	1,16	1,25	1,35	1,45	1,50	1,50
45°C	0,38	0,45	0,53	0,60	0,68	0,75	0,83	0,90	0,98	1,05	1,13	1,20	1,28
50°C	0,30	0,36	0,42	0,48	0,54	0,60	0,66	0,72	0,78	0,84	0,90	0,96	1,02

Example: Compressed air to be dried.

a) To calculate the max. dryer capacity

Volume flow	22 m ³ /h	$V_{\text{corr}} = \frac{V_{\text{norm}}}{f} = \frac{22 \text{ m}^3/\text{h}}{1,50} = 14,66 \text{ m}^3/\text{h}$
Min. operating pressure	10 bar (ü)	
Max. inlet temperature	+30°C	
Factor from table	1.50	
		Selected type DAU 3 N.

Adsorption dryers **DAV 75** to **DAV 2415**

Externally heated with vacuum regeneration including pre-filter and after-filter

Flow capacity: 420 – 14500 m³/h, 241 – 8359 cfm

Max. operating pressure: 10 bar, 150 psig



FILTRATION

The entire range is equipped with both pre and after filter as standard. Which means before drying, all solids and aerosols up to 0.01 µm are removed from the compressed air supply – assuring best possible quality.

FUNCTIONAL DISPLAY

The innovatively designed controller, clearly displays operating parameters such as pressure, temperature, cycle, vacuum pump, and changeover – for safe and efficient operation.

PRESSURE DEW POINT

The pressure dew point is extremely reliable because the regeneration ambient air is drawn through the dryer inlet in the same direction as the air to be dried.

MODULAR SYSTEM

Options: controlled regeneration air; thyristor controlled heating; variable speed vacuum pump motor.

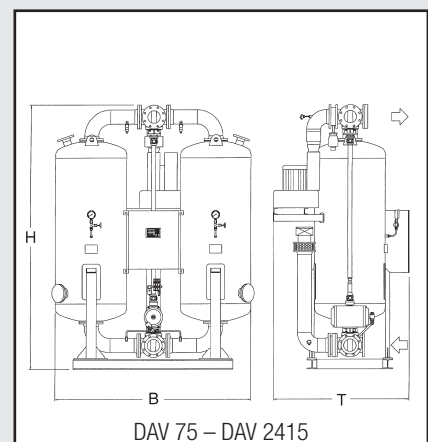

DAV 75 – DAV 2415

Equipment

- Two-layer desiccant bed, balanced between water resistance and high efficiency water retention.
- Active heating under vacuum-vaporizing temperature at 98°C.
- Low regeneration temperature of the desiccant bed.
- Intensive cooling using vacuum without any heat generation from the vacuum pump.
- Pressure build-up on the wet side assures no purge air even in the build-up phase.
- Changeover without pressure dew point peak. Moisture in the regeneration air and cooling phase never reaches the drying zone.

Energy efficient: Heat regenerated adsorption dryers are ideally suited for higher outputs and pressure dew points up to -70°C (standard -25°C or -40°C). Ambient air is taken and heated under vacuum to regenerate the desiccant. This process enables efficient compressed air drying resulting in energy savings of up to 25 percent in comparison with traditional systems.

BOGE Type	Volume of flow*			Connection	Width W mm	Height H mm	Depth D mm	Weight without Filter kg	Power required kWh/h
	m ³ /min	m ³ /h	cfm						
DAV 75	7,0	420	241	DN 40	1215	1955	992	460	3,1
DAV 85	8,5	510	293	DN 40	1214	2204	992	560	3,8
DAV 105	10,7	640	370	DN 50	1306	2247	1082	750	5,2
DAV 145	14,2	850	487	DN 50	1360	2271	1120	800	6,7
DAV 200	19,7	1180	681	DN 80	1560	2664	1264	1150	10,9
DAV 250	25,0	1500	863	DN 80	1610	2680	1279	1350	12,8
DAV 330	33,0	1980	1141	DN 80	1700	2730	1585	1720	16,3
DAV 390	39,2	2350	1353	DN 100	2020	2845	1447	1880	18,1
DAV 455	48,8	2930	1688	DN 100	2080	2870	1580	2350	22,5
DAV 555	59,2	3550	2047	DN 100	2170	2940	1740	2850	27,8
DAV 685	68,3	4100	2365	DN 150	2450	3190	1780	4000	32,2
DAV 790	79,0	4740	2735	DN 150	2550	3210	2110	4100	38,9
DAV 875	87,5	5250	3029	DN 150	2550	3230	1955	4200	44,9
DAV 1035	103,5	6210	3582	DN 150	2600	3500	1910	4950	52,3
DAV 1185	118,3	7100	4094	DN 150	2650	3520	1940	5700	56,4
DAV 1335	133,3	8000	4611	DN 200	3100	3585	2180	6400	67,1
DAV 1535	153,3	9200	5306	DN 200	3150	3605	2300	7400	75,6
DAV 1800	180,0	10800	6224	DN 200	3250	3670	2355	8700	85,3
DAV 2050	205,0	12300	7088	DN 250	3500	3855	2515	11500	98,9
DAV 2415	241,7	14500	8359	DN 250	3600	3895	2570	13500	111,4

* m³/h at 1 bar to DIN 7183. Higher capacities and lower pressure dewpoints down to -70°C are available upon request.
Receiver as per PED individual acceptance / CE standard

Conversion factors, depending on pressure and temperature

Temperature	Operating pressure bar (g)						
	4	5	6	7	8	9	10
30°C	0,69	0,80	0,90	1,02	1,06	1,17	1,29
35°C	0,44	0,62	0,80	1,00	1,05	1,16	1,28
40°C	0,28	0,42	0,59	0,70	0,79	0,88	0,96

Example: Compressed air to be dried.

a) To calculate the max. dryer capacity

Volume flow 3000 m³/h
 Min. operating pressure 5 bar (g)
 Max. inlet temperature +30°C
 Pressure dew point -25°C
 Factor from table 0.80

$$\frac{\text{eff. capacity}}{\text{factor from table}} = \frac{3000 \text{ m}^3/\text{h}}{0.80} = 3750 \text{ m}^3/\text{h}$$

Selected type DAV 685.

b) To calculate the max. dryer capacity

Nominal capacity x factor from table
 (DAV 685) = 4100 m³/h x 0.80 = 3280 m³/h

c) Reserve dryer capacity

max. dryer capacity – volume flow
 3280 m³/h - 3000 m³/h = 280 m³/h

Cyclone separator Z 20 to Z 375



LAYOUT

The cyclone separator is ideally suited as a bulk water separator when located before a refrigerant dryer or directly after the compressor if no air receiver is used; or if it is placed at a distance; or if the compressed air supply pipe is mounted vertically.

EFFICIENCY

Apart from the drain, the cyclone separator operates wear free because there are no moving parts which means increased output of the compressed air treatment system.

MINIMAL PRESSURE LOSS

There is a minimal pressure loss across a cyclone separator which means that operating pressure is always optimised – saving energy.

BEKOMAT

An electronically level controlled, loss-free, Bekomat condensate drain can be fitted as an option assuring increased compressed air treatment safety.



Operating principle

The cyclone separator works according to the mass inertia principle. It consists of a vortex cartridge and a reservoir. The vortex cartridge induces the compressed air into rotary movement. Solid and liquid components in the air are forced against the inside walls of the separator by their own mass inertia. This causes heavy particles of dirt and water to separate and flow into the collection reservoir.

Maintenance free filtration: The BOGE heavy-duty cyclone separators takes liquids, aerosols and solids from the compressed air. Based on the law of inertia they operate with practically no maintenance – ideally suited for compressed air systems without an air receiver when directly installed downstream of the compressor.

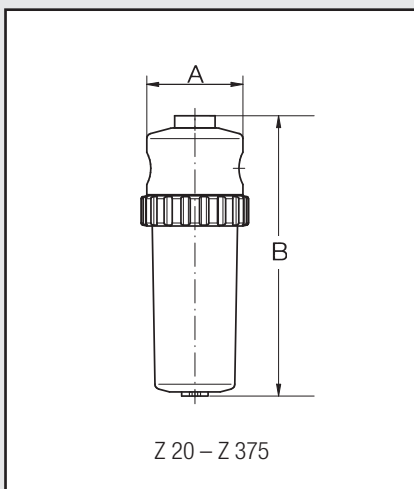

BOGE Type	Flow capacity* m ³ /min at			Compressed air connection	Max. operating pressure bar	Dimensions	
	8 bar	10 bar	13 bar			A mm	B mm
Z 20	2,28	2,91	3,64	G 1/2	16	80	260
Z 40	4,13	5,25	6,56	G 3/4	16	95	280
Z 65	6,88	8,75	10,93	G 1	16	110	355
Z 90	10,08	12,84	16,03	G 1 1/4	16	110	355
Z 125	13,75	17,50	21,88	G 1 1/2	16	150	470
Z 170	18,26	23,24	29,05	G 2	16	150	470
Z 275	30,25	38,50	48,13	G 2 1/2	16	180	580
Z 375	41,25	52,92	65,63	G 3	16	180	580

* relates to the compressor's intake condition (+ 20°C, 1 bar)

Pre-filters **V 5** to **VF 490** Microfilter and Activated Carbon Filters **FP 5/A 5** to **FFP 490/AF 490**



Pre-filter **V**

EFFICIENT

BOGE pre-filters are 99.99 percent efficient based on 3 µm, thus providing optimal conditions for further compressed air treatment.

LAYOUT

It is recommended that a pre-filter is positioned upstream of the compressed air dryer and the microfilter. They are essential when ambient air is extremely dusty or when high oil carry over is a risk.



Microfilter **FP** and active carbon filter **A**

EFFICIENT

BOGE microfilters are 99.99 percent efficient based on 0.01 µm. The residual oil content after a microfilter is 0.01 mg/m³, and reduced to 0.005 mg/m³ when used in combination with active carbon filters.

LAYOUT

Microfilters with or without active carbon filters are best used as main filters in the compressed air line or as point of use filters.

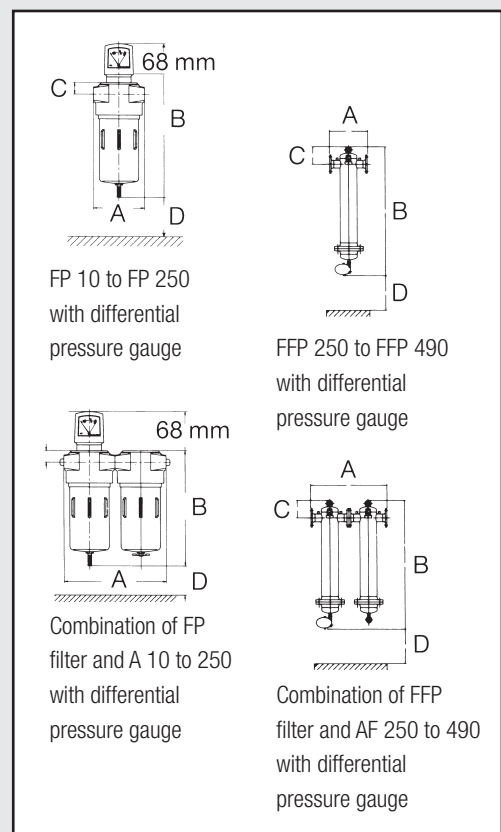
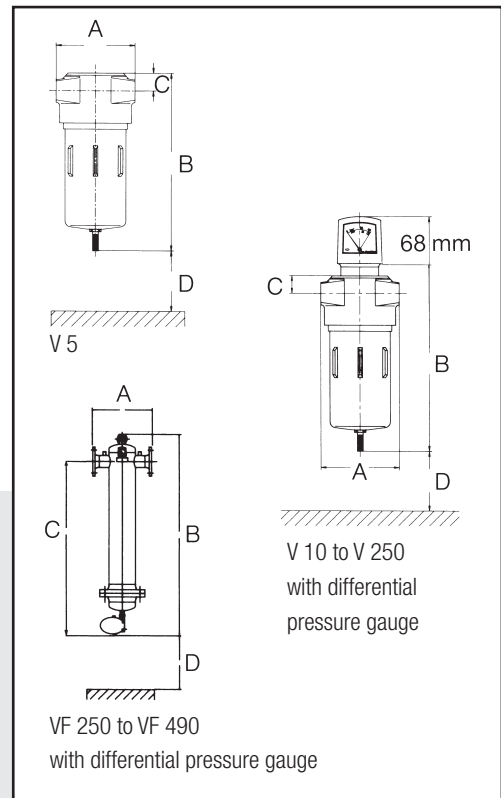

Differential pressure and efficiency

	FP Series	A Series	FP/A Series
Differential pressure in clean condition	Δp 0,06 bar	Δp 0,03 bar	Δp 0,2 bar
Efficiency	99,99999 % relative to 0,01 µm Residual oil content max. 0,01 mg/m ³	Residual oil content = 0,003 mg/m ³	99,99999 % relative to 0,01 µm

Higher pressures and capacities are available upon request

For ultra clean compressed air in extreme conditions: Compressed air treatment is achieved in several stages. Pre-filters are used to separate coarse impurities from the compressed air. Smaller solids and oil can be removed by means of microfilters. Finally active carbon filters are used to clean oil vapours, aromatics, flavourings and odours from the compressed air. This assures oil free and clean compressed air even in extreme conditions!

BOGE Type ¹⁾	Capacity ²⁾ m ³ /h	Connection	Dimensions in mm				Weight kg	Filter element/Number
			A	B	C	D		
Aluminium housing with threaded connector as per DIN 2999								
V 5	30	G ¼	60	167	14	60	0,8	1/5 V
V 10	50	G ¼	87	209	21	75	1,5	1/10 V
V 12	70	G ⅜	87	209	21	90	1,5	1/12 V
V 20	100	G ½	87	279	21	160	1,7	1/20 V
V 30	180	G ¾	130	315	43	135	4,3	1/30 V
V 50	300	G 1	130	415	43	235	5,0	1/50 V
V 80	470	G 1½	130	515	43	335	5,5	1/80 V
V 120	700	G 1½	130	715	43	525	6,9	1/120 V
V 160	940	G 2	164	823	48	520	9,6	1/160 V
V 250	1450	G 2	164	1073	48	770	17,9	1/250 V
Steel housing with flanged connector as per DIN 2633								
VF 250	1850	DN 80	380	1260	175	530	54,0	1/250 V
VF 400	2920	DN 80	440	1310	205	530	80,0	1/400 V
VF 490	3700	DN 100	500	1440	230	550	108,0	2/250 V

Max. operating pressure 16 bar, ¹⁾ incl. automatic condensate drain, differential pressure gauge from V 10 onwards, ²⁾ relative to 20 °C and 1 bar absolute at 7 bar over pressure

Conversion factor f at other operating pressures

bar Over-pressure	1	2	3	4	5	6	7	8	9	10
f =	0,25	0,38	0,5	0,63	0,75	0,88	1,00	1,13	1,25	1,38

Differential pressure and efficiency	
Differential pressure in clean condition	Δp 0,02 bar
Efficiency	99,99 % relative to 3 μm

Higher pressures and capacities are available upon request

BOGE Type ¹⁾	Capacity ²⁾ m ³ /h	Connection	Dimensions in mm				Combination FP/A in mm A	Weight kg	Weight Combination FP/A kg	Filter element Number/Type FP or A
			A	B	C	D				
Aluminium housing with threaded connector as per DIN 2999										
FP 5/A 5	30	G ¼	60	165	14	60	120	0,8	1,6	1/ 5 FP/A
FP 10/A 10	50	G ¼	87	215	21	75	174	1,5	3,0	1/ 10 FP/A
FP 12/A 12	70	G ⅜	87	215	21	90	174	1,5	3,0	1/ 12 FP/A
FP 20/A 20	100	G ½	87	285	21	160	174	1,7	3,4	1/ 20 FP/A
FP 30/A 30	180	G ¾	130	325	43	135	260	4,3	8,9	1/ 30 FP/A
FP 50/A 50	300	G 1	130	425	43	235	260	5,0	10,7	1/ 50 FP/A
FP 80/A 80	470	G 1½	130	525	43	335	260	5,5	11,6	1/ 80 FP/A
FP 120/A 120	700	G 1½	130	725	43	525	260	6,9	14,2	1/120 FP/A
FP 160/A 160	940	G 2	164	825	48	520	340	9,6	19,7	1/160 FP/A
FP 250/A 250	1450	G 2	164	1075	48	770	340	17,9	25,8	1/250 FP/A
Steel housing with flanged connector as per DIN 2633										
FFP 250/AF 250	1850	DN 80	380	1280	175	530	760	54,0	108	1/250 FP/A
FFP 400/AF 400	2920	DN 80	440	1320	205	530	880	80,0	160	1/400 FP/A
FFP 490/AF 490	3700	DN 100	500	1440	230	550	1000	108,0	215	2/250 FP/A

Max. operating pressure 16 bar, ¹⁾ incl. automatic condensate drain on model FP 5 onwards, differential pressure gauge on model FP 10 onwards, ²⁾ relative to 20 °C and 1 bar absolute at 7 bar over pressure, technical data for series FP and A are identical

Conversion factor f at other operating pressures

bar Over-pressure	1	2	3	4	5	6	7	8	9	10
f =	0,25	0,38	0,50	0,63	0,75	0,88	1,00	1,13	1,25	1,38

Activated Carbon Adsorbers

DCZ 4 to DCZ 161

Flow capacity: 8 – 940 m³/h, 5 – 553 cfm

Max. operating pressure: 16 bar, 230 psig



OPTIMISED METHOD

A deep, premium quality, active carbon bed combined with an optimised air flow speed are the prerequisites for absolutely reliable compressed air treatment.

LONG SERVICE LIFE

To protect against oil and water droplets and to extend the service life, BOGE microfilters should be installed upstream of the activated carbon adsorber.

OIL CHECK INDICATOR

The activated carbon adsorber is equipped as standard with an oil check indicator for permanent compressed air quality monitoring.

PRE-FILTERS

For ultimate protection and compressed air quality a BOGE pre-filter should be installed downstream of the active carbon adsorber. This prevents any migration of carbon dust.

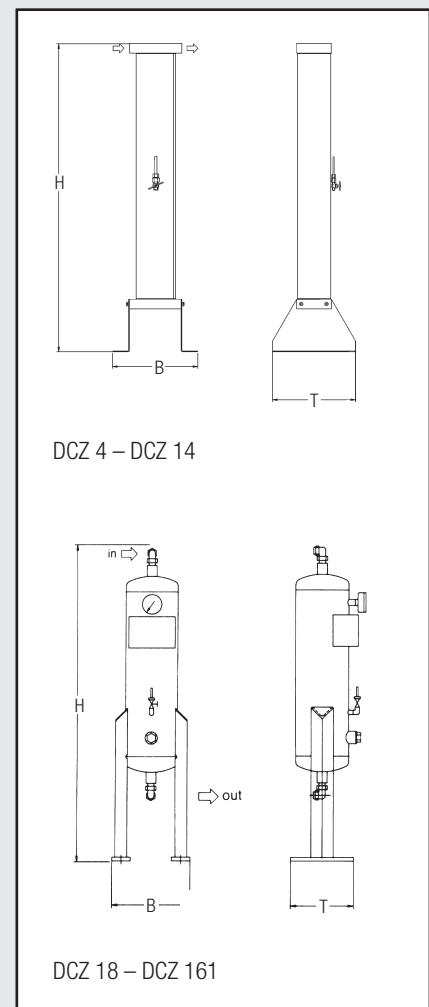

Ensures clean compressed air with a long service life: For compressed air with the lowest residual oil content (0.003 mg/m³) the activated carbon adsorber is the right choice for your compressed air treatment system because they are designed to eliminate oil aerosols that may have penetrated the intake air.

The BOGE activated carbon adsorbers are ideal for the most stringent air quality requirements.

BOGE Type	Capacity*		Dimensions W x D x H mm	Connection	Max. Pressure bar	Weight kg
	m ³ /h	cfm				
DCZ 4	8	5	219 x 210 x 390	G 1/4	16	2,9
DCZ 5	15	9	219 x 210 x 565	G 1/4	16	4,4
DCZ 6	25	15	219 x 210 x 815	G 1/4	16	6,0
DCZ 8	35	21	219 x 210 x 1065	G 1/4	16	9,0
DCZ 9	56	33	313 x 300 x 1185	G 3/8	16	23,0
DCZ 11	72	42	313 x 300 x 1410	G 3/8	16	28,0
DCZ 14	86	50	313 x 300 x 1610	G 1/2	16	33,0
DCZ 18	105	62	245 x 400 x 1380	G 1	16	45,0
DCZ 26	145	85	265 x 300 x 1630	G 1	16	50,0
DCZ 36	200	118	270 x 400 x 1645	G 1	16	65,0
DCZ 46	255	150	300 x 400 x 1705	G 1	16	95,0
DCZ 61	350	206	325 x 400 x 1740	G 1 1/2	16	105,0
DCZ 71	420	247	355 x 500 x 1755	G 1 1/2	16	120,0
DCZ 101	620	365	410 x 500 x 1795	G 1 1/2	16	160,0
DCZ 126	750	441	440 x 500 x 1930	G 2	16	200,0
DCZ 161	940	553	490 x 500 x 1950	G 2	16	250,0

Higher capacities are available upon request

* m³/h at 1 bar to DIN ISO 7183

Receiver as per PED individual acceptance / CE standard

Conversion factor: Pressure

bar	4	5	6	7	8	9	10	12	14	16
Factor P	0,62	0,75	0,89	1,00	1,08	1,26	1,36	1,62	1,79	2,14
Temp. °C	20	25	30	35	40	45	50			
Factor T	1,01	1,01	1,01	1,00	0,85	0,75	0,50			

Example: Aerosols to be separated from the compressed air

a) To calculate the right adsorber capacity

Volume flow	150 m ³ /h	$\frac{\text{eff. capacity}}{\text{factor P} \times \text{T}} = \frac{150 \text{ m}^3/\text{h}}{1.08 \times 0.85} = 163.4 \text{ m}^3/\text{h}$
Min. operating pressure	8 bar (g)	
Max. inlet temperature	+40°C	
factor P from table	1.08	Selected type DCZ 36.
factor T from table	0.85	

Converters **BC 1** to **BC 12 HP**



BC 2



BC 4



BC 50

HIGH OPERATING DEPENDABILITY

The system is absolutely safe and the migration of oil into the compressed air system is impossible. Installation directly downstream of compressor is ideal.

OIL FREE CONDENSATE

Any condensate generated in the process is absolutely oil-free to a drinking water quality. This completely eliminates condensate disposal costs.

MAINTENANCE FRIENDLY

With an expected service life of 15,000 operating hours maintenance is reduced to an absolute minimum. Additionally, the converter does not use a filter, which means there are no filter element changes ever required.

EFFICIENCY

The converter has an energy consumption of approximately 5 watt/m³. There is no compressed air loss through the filter, either, which helps to optimise generation pressure.

Typical applications:

- blowing air (PET)
- medical science (breathing air)
- food industry
- pharmaceutical industry
- chemical industry
- electronics industry
- and many more

Absolute oil free ecologically friendly air: The BOGE converter offers alternative possibilities for the production of absolutely oil-free compressed air to achieve quality class 1 (ISO 8573-1). The investment and operating costs of a BC converter are lower when compared to a traditional treatment system and it will run absolutely trouble free! Also due to an innovative catalyst system only ultra clean condensate is produced – meaning the system is absolutely environmentally friendly!



OPERATING PRINCIPLE

The catalyst system in the BOGE converter splits the long hydrocarbon chains of oil contained in the compressed air into carbon dioxide and water – natural substances present in our atmosphere. The catalyst material is compact granules in a container with compressed air circulating around it. In the process, both oil droplets and oil aerosols are cracked providing absolutely oil free compressed air and resultant condensate.

BOGE Type	Flow rate at		Max. over-pressure bar	Con-nection	Installed power kW	Fuse protection A	Supply voltage V	Specific power input kWh/m ³	Pressure lost bar	Dimensions W x D x H mm	Weight kg
	7 bar m ³ /min	45 bar m ³ /min									
BC 1	1	–	15	Ø15 mm	1,2	10	230	0,010	≈ 0,5	650x461x1138	130
BC 2	2	–	15	G 1	5,0	16	400	0,010	≈ 0,5	965x400x1518	240
BC 4	4	–	15	G 1 1/4	5,0	16	400	0,010	≈ 0,5	965x400x1518	260
BC 7	7	–	15	G 1 1/2	5,0	16	400	0,010	≈ 0,6	1075x580x1718	330
BC 10	10	–	15	G 1 1/2	7,0	20	400	0,007	≈ 0,6	1075x580x1718	380
BC 15	15	–	15	DN 50	10,0	20	400	0,007	≈ 0,6	1460x710x1950	600
BC 20	20	–	15	DN 65	14,0	32	400	0,007	≈ 0,5	1460x710x1950	710
BC 25	25	–	15	DN 65	18,0	32	400	0,007	≈ 0,5	1460x710x1950	800
BC 40	40	–	15	DN 80	28,0	64	400	0,005	≈ 0,5	2220x900x2240	1500
BC 50	50	–	15	DN 100	28,0	64	400	0,005	≈ 0,5	2244x900x2240	1700
BC 6 HP	–	6	45	G 1	1,2	10	230	0,010	≈ 2,5	965x400x1518	130
BC 12 HP	–	12	45	G 1	5,0	16	400	0,006	≈ 2,5	965x400x1518	240

For differing operating pressures the following conversion factors should be applied:

Factors for 7-bar versions (BC series)

Working pressure bar	4	5	6	7	8	9	10	11	12	13	14	15	
Factor	f1	0,63	0,75	0,88	1,00	1,13	1,25	1,38	1,50	1,63	1,75	1,88	2,00

Factors for 45-bar versions (BC...HP series)

Working pressure bar	5	10	20	30	40	45	
Factor	f1	0,13	0,24	0,46	0,67	0,89	1,00

Example:

Compressor: S 40-2, Pressure: 10 bar, free air delivery: 4,63 m³/min

Conversion factor: 1.38

Selected converter: BC 4, nominal capacity at 7 bar: 4 m³/min

Conversion of converter flow rate: 4 m³/min x 1.38 = 5.52 m³/min

(= max. permissible FAD of connected compressor)

Calculation of min. flow rate (70 %) of BC 4: 0.7 x 5.52 m³/min = 3.86 m³/min

(= required min. FAD of connected compressor)

BOGE compressed air treatment equipment

BOGE compressed air receivers



Filter/Water separators (max. 16 bar)

Compact design. Connections either side for easy installation.
Manual or automatic condensate drainage.

Size of connection		G 1/4	G 3/8	G 1/2	G 3/4
Dimensions: Length installed	Width mm	40	48	70	70
	Height mm	120	158	202	202
Rating at 6 bar pressure (p ₁) and pressure drop $\Delta p = 1$ bar		m³/min			
		1,8	2,0	3,2	3,5



Pressure relief valve with gauge (max. 25 bar)

Compact design. Connections either side for easy installation.
Simple locking device when adjusting pressures.

Size of connection		G 1/4	G 3/8	G 1/2	G 3/4
Dimensions: Length installed	Width mm	40	48	70	70
	Height mm	105	98	134	134
Rating at 10 bar pressure (p ₁), 6 bar secondary pressure (p ₂) and pressure drop $\Delta p = 1$ bar according to DIN ISO 6953		m³/min			
		2,0	3,2	7,0	8,0



Lubricator (max. 16 bar)

Compact design. Integrated quantity compensation.
Connections either side for easy installation.

Size of connection		G 1/4	G 3/8	G 1/2	G 3/4
Dimensions: Length installed	Width mm	40	48	70	70
	Height mm	140	171	224	224
Rating at 6 bar pressure (p ₁) and pressure drop $\Delta p = 1$ bar		m³/min			
		3,4	4,4	4,6	7,5



Combined (filter/pressure relief valve with gauge) (max. 16 bar)

Compact design. Manual or automatic condensate discharge.
Pressure relief valve has secondary venting. Simple locking device when adjusting pressures.

Size of connection		G 1/4	G 3/8	G 1/2	G 3/4
Dimensions: Length installed	Width mm	40	48	70	70
	Height mm	175	203	273	273
Rating at 10 bar pressure (p ₁), 6 bar secondary pressure (p ₂) and pressure drop $\Delta p = 1$ bar according to DIN ISO 6953		m³/min			
		2,0	3,0	5,5	6,5

Accessories: Fastening bracket (wall mounting), coupling set, 30 micron filter set, 5 micron filter set, 30 micron filter/regulator cartridge, 5 micron filter/regulator cartridge.

Galvanised compressed air receivers

11 bar and 16 bar operating pressures

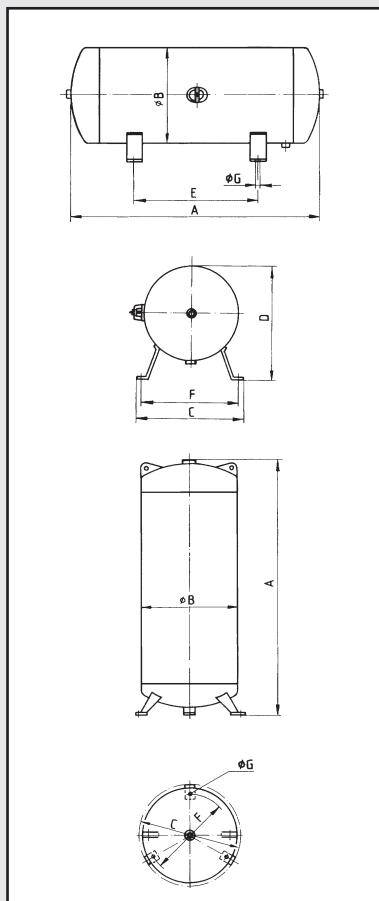

Capacity Litres	Dimensions in mm							Weight kg	Air inlet	Air outlet Ball	Inspections apertures
	A	ØB	C	D	E	F	ØG				
Horizontal receivers, galvanised compressed air receivers, 11 bar											
50	780	300	380	380	400	320	14	30	G 1/2	G 3/8	2 x 1 sleeve on the back
90	995	350	390	500	550	330	14	37	G 3/4	G 3/8	
150	1360	400	410	480	800	350	14	66	G 1/2	G 1/2	
270	1540	500	570	625	800	500	19	100	G 1/2	G 1/2	1 hand hole
350	1610	550	620	660	900	550	19	125	G 3/4	G 3/4	
500	1730	600	670	705	1100	600	24	150	G 1 1/4	G 1	
750	1828	750	730	856	1100	660	24	220	G 1 1/4	G 1	
1000	2070	800	790	885	1200	720	24	285	G 1 1/4	G 1 1/4	2 hand holes or 1 manhole (option)
2000	2170	1150	1200	1325	1300	1100	23	555	G 1 1/2	G 2	
3000	2675	1250	1350	1450	1500	1250	23	765	G 1 1/2	G 2	
5000	3500	1400	1500	1600	2200	1400	23	1170	G 1 1/2	G 2	1 manhole
10000	5370	1600	1600	1700	3700	1550	18	2100	DN 100	DN 100	
	A	ØB	C	F	ØG	height installed					

Vertical receivers, galvanised compressed air receivers, 11 bar											
270	1765	500	500	460	13	1780		100	G 1	G 1/2	1 hand hole
350	1835	550	550	510	13	1845		125	G 1	G 3/4	
500	1980	600	655	525	22	2070		150	G 1 1/2	G 1 1/2	
750	2084	750	750	620	22	2130		220	G 1 1/2	G 1 1/2	
1000	2340	800	800	670	22	2400		285	G 1 1/2	G 2	2 hand holes or 1 manhole (option)
2000	2390	1150	1000	1000	23	2510		555	G 2 1/2	G 2 1/2	
3000	2790	1250	1250	1150	23	2865		765	G 2 1/2	G 2 1/2	
5000	3730	1400	1400	1300	23	3800		1170	G 2 1/2	G 2 1/2	1 manhole
5000	3730	1400	1400	1300	23	3800		1180	DN 100	DN 100	
10000	5590	1600	1600	1340	-	5660		2100	DN 100	DN 100	

Capacity Litres	Dimensions in mm							Weight kg	Air inlet	Air outlet Ball	Inspections apertures
	A	ØB	C	D	E	F	ØG				
Horizontal receivers, galvanised compressed air receivers, 16 bar											
50	780	300	380	380	400	320	14	37	G 1/2	G 3/8	2 x 1 sleeve on the back
150	1310	400	410	480	800	350	14	74	G 1/2	G 1/2	
250	1380	500	570	625	800	500	19	113	G 3/4	G 1/2	1 hand hole
350	1600	550	620	660	900	550	19	145	G 3/4	G 3/4	
500	1780	600	670	705	1100	600	24	180	G 1 1/4	G 1	
750	1860	750	730	856	1100	660	24	275	G 1 1/4	G 1	
1000	2100	800	790	885	1200	720	24	355	G 1 1/4	G 1 1/4	2 hand holes or 1 manhole (option)
2000	2170	1150	1200	1325	1300	1100	23	720	G 1 1/2	G 2	
3000	2675	1250	1350	1450	1500	1250	23	935	G 1 1/2	G 2	
5000	3270	1400	1500	1600	2200	1400	23	1340	G 1 1/2	G 2	1 manhole
10000	5370	1600	1600	1700	3700	1550	18	2940	DN 100	DN 100	
	A	ØB	C	F	ØG	height installed					

Vertical receivers, galvanised compressed air receivers, 16 bar											
250	1605	500	500	380	13	1615		113	G 1	G 1/2	1 hand hole
350	1835	550	550	510	13	1845		145	G 1	G 3/4	
500	1995	600	600	525	22	2100		180	G 1 1/2	G 1 1/2	
750	2110	750	750	620	22	2155		275	G 1 1/2	G 1 1/2	
1000	2340	800	800	670	22	2400		355	G 1 1/2	G 2	2 hand holes or 1 manhole (option)
2000	2410	1150	1150	1000	23	2510		720	G 2 1/2	G 2 1/2	
3000	2790	1250	1250	1150	23	2865		935	G 2 1/2	G 2 1/2	
5000	3730	1400	1400	1300	23	3800		1340	G 2 1/2	G 2 1/2	1 manhole
5000	3730	1400	1400	1300	23	3800		1350	DN 100	DN 100	
10000	5590	1600	1600	1340	-	5660		2940	DN 100	DN 100	

Compressed air receivers with higher operating pressures are available upon request

BOGE condensate drains



Float operated condensate drains

NO COMPRESSED AIR LOSSES

Float operated drains only open when there is condensate to remove. That means that compressed air losses are avoided.

SIMPLE OPERATING PRINCIPLE

Float operated drains work very simply however they are more sensitive to dirt and require regular maintenance.



Bekomat electronic level-controlled condensate drains

ZERO COMPRESSED AIR LOSSES

An electronic sensor ensures the drain only works when there is condensate to discharge – this is done without any air losses. The intelligent electronic controller ensures loss free discharge and also monitors the condition of the drain.

CONTROL FUNCTION

An LED display indicates the operating condition of the drain. A potential free contact (not available in Bekomat 31) allows remote monitoring – for high operating safety.

Level controlled condensate drains: Condensate is a by-product of compressing air. The amount produced depends entirely on humidity, ambient temperatures and the volume of air generated. Condensate is produced in different quantities in different places within the compressed air network, i.e. when the temperature of the compressed air falls below the pressure dew point. Due to their absolute reliability BOGE condensate drains stand for safe and efficient condensate management.

Float-controlled	
Float drain	Ø 85 mm, H = 185 mm
Connection	In G 1/2, Out G 3/8

Electronic level controlled

BOGE Type	Max. compressor output m ³ /min	Max. dryer output m ³ /min 100% saturated	use for*	Dimensions in mm W x D x H	Connection In/Out
Bekomat 31	2,5	5,0	a, b	164 x 65 x 118	G 1/2 / G 1/4
Bekomat 32	5,0	10,0	a, b	179 x 74 x 127	G 1/2 / G 1/4
Bekomat 12	6,3	12,6	a	65 x 150 x 141	G 1/2 / G 3/8
Bekomat 13	280,0	56,0	a	93 x 212 x 162	G 1/2 / G 1/2
Bekomat 14	126,0	252,0	a	120 x 252 x 180	G 3/4 / G 1/2
Bekomat 16 CO	1400,0	2800,0	a, b	280 x 280 x 280	G 3/4 / G 1/2

* Output figures based on central European climate conditions
a = condensate with oil
b = oilfree, aggressive condensate

BOGE Oil/Water separator



LARGE OVERFLOW

The large overflow is designed to prevent emulsions from impairing the function of the oil/water separator. Oil backup in the filter is thus avoided.



FILTER MONITORING

The oil/water separator is equipped with an integrated level indicator for filter monitoring in order to ensure safe operation.

EFFICIENCY

BOGE oil/water separators are available in a number of sizes. They require no energy nor too much maintenance.

OPTIMUM SEPARATION

A simple visual test indicates whether the filter is due for replacement. Comparing samples quickly determines the relative turbidity and whether or not the filter efficiency is still adequate.

Let gravity do the job: Legislation demands that compressor condensate must be treated prior to discharge into a foul water network. In the case of a simple suspension oil can be separated from water by gravity, on site, by using a cost effective BOGE oil/water separator.



The compressor condensate flows under pressure into the newly designed pressure relief chamber (1) where the pressure is relieved to atmosphere without causing any internal turbulence (2). Coarse dirt particles are retained in a removable collection pan (3). Gravity causes the oil to separate and rise to the surface in the reservoir. Oil then flows into the overflow proof oil collection reservoir (4). The pre-cleaned condensate flows into the filter stage. The condensate flows from the inside to the outside of the pre-filter (5) and embeds any remaining oil droplets in its material. Additionally, any floating oil is gathered in the filter chamber. These remaining oil particles are safely and reliably retained in the main filter cartridge (6) so that the remaining water, now fit for direct discharge, can be released into the foul water drain. The filter cartridge is quick and very simple to exchange.

BOGE Type	Piston compressors (VDL 150) Max. compressor output in m ³ /min	Piston compressors (Syprem 8000 K) Max. compressor output in m ³ /min	Screw compressors Max. compressor output in m ³ /min	Dimensions W x D x H mm
ÖWAMAT 10	1,7	1,7	1,9	220 x 222 x 528
ÖWAMAT 11	3,4	3,2	3,8	375 x 254 x 595
ÖWAMAT 12	5,1	4,9	5,6	544 x 350 x 702
ÖWAMAT 14	10,1	9,7	11,3	594 x 410 x 872
ÖWAMAT 15	20,3	19,4	22,5	764 x 520 x 1090
ÖWAMAT 16	40,5	38,8	45,0	939 x 650 x 1160

Output details for central European climate.

READY FOR ACTION WORLDWIDE:

BOGE Service Support – Worldwide



BOGE
COMPRESSED AIR SYSTEMS

SERVICE

Service / Maintenance

Service support solutions including contracts covering repair and even warranty extension. Routine maintenance according to our flat rate service plan as well as inspection and breakdown cover.

Extended Warranty

Extension of your factory warranty up to 5 years with the BOGE cairplan: for total security and back-up (see overleaf for more details).

Comprehensive Service Cover

The comprehensive “cair” package includes a guaranteed reaction time within the warranty period.

Maintenance & Repair

Options include; long-term fixed cost maintenance plans, a flat rate for all types of service and spare parts with a possible warranty extension up to 10 years.

Commissioning

Connection and adjustment of all equipment at your facility: a fast and dependable service delivered by qualified BOGE service technicians. Full installation on request.

24 Hour Helpline

Emergency helpline for trouble shooting and technical support: available any time around the clock!

COMPRESSED AIR FLAT RATE

A comprehensive service plan created to satisfy your individual requirements: e.g. taking responsibility for the compressed air station at your facility including complete plant management for a monthly flat rate irrespective of hours of operation (energy costs not included).

FLEXIBLE SERVICE

This BOGE service programme has been developed to adapt to each customer's unique requirements. It is our objective to create a tailor-made BOGE service package covering inspection, service, breakdown, with customised warranty arrangements as well as complete all-in service contracts.

Please contact us to help you determine the type of service best suited to meet your needs: Just email us at service@boge.de – our service specialists will be in touch with you shortly!

Service your added value! Maximised reliability and economic efficiency are not the only technical advantages that BOGE has to offer. Our comprehensive service support program will ensure your BOGE compressed air system remains in tip top condition. Wherever you need us, whatever we can do for you: BOGE Service Support is always readily available close by – competent, to the highest standards, and always one step ahead.



BOGE CAIRPLAN

BOGE cairplan enables you to extend your factory warranty up to 5 years: 2 years factory warranty with 3 years additional cairplan warranty – the choice is yours. Furthermore, cairplan ensures manufacturer’s recommended maintenance schedule of new and existing equipment at the specified service intervals.

For more information email
cairplan@boge.com



BOGE ORIGINAL PARTS

Only original BOGE spare parts have the manufacturer’s technological edge. You can be confident when opting for BOGE original spare parts in the service of your BOGE compressed air system will ensure that the integrity of the compressor is maintained, efficiency is retained and your peace of mind is sustained.



ALWAYS NEARBY

BOGE has a network of dedicated service technicians and certified partners at its disposal to help you worldwide with your installation, upgrading, commissioning or approval, maintenance, repair, or inspection: You can rely on the know-how and experience of our qualified experts – at all times.

Hotline Mobile Service: +49 5206 601-130



EMERGENCY ASSISTANCE

In the case of an emergency where immediate technical support is required, the BOGE product support trouble shooters or the BOGE Helpline team are available to you 24/7.

Product Support Hotline:
+49 5206 601-140
BOGE Helpline: +49 170 4400444



AIR AUDITS

By analysing your existing compressed air system, our energy efficiency experts can identify where savings can be made. The BOGE AIRreport includes measurement of: dew point control, vibration control, leakage, noise, oil check and TAN check.



TRAINING COURSES

The BOGE Compressed Air College was established in order to train and certify internal employees and external partners as qualified BOGE Service Technicians. Attendance of training courses held in the in-house training centre further assist in refreshing existing BOGE Service Technician’s knowledge at regular intervals.

For four generations, customers from mechanical engineering, industry and trade have relied on BOGE know-how when it comes to planning, developing and manufacturing compressed air systems. They are fully aware of the fact that BOGE AIR is more than just ordinary compressed air: utmost safety, outstanding efficiency, excellent quality, maximised flexibility along with dependable service are the ingredients to transform BOGE AIR into air to work with – in Germany, in Europe and in more than 80 countries around the world.

Our ranges of services include the following:

- Energy efficient systems development
- Plant design and engineering
- System control and visualisation
- Oil-free piston, screw and turbo compressors
- Oil injected screw compressors
and oil lubricated piston compressors
- Compressed air treatment
- Compressed air distribution and storage
- Compressed air accessories
- Compressed air service



BOGE KOMPRESSOREN

Otto Boge GmbH & Co. KG

P.O. Box 10 07 13 · 33507 Bielefeld

Otto-Boge-Straße 1–7 · 33739 Bielefeld

Fon +49 5206 601-0 · Fax +49 5206 601-200

info@boge.de · www.boge.de